



## Accessory Fitting Instructions

Tank Pad Kit	
Kit Number	Models Affected
A9798025 A9790116	Speed Triple S, Speed Triple R, Speed Triple RS
A9790094	Speed Triple 1200 RS, Speed Triple 1200 RR
A9798051	Tiger 1200 GT Explorer, Tiger 1200 Rally Explorer

Thank you for choosing this Triumph genuine accessory kit. This accessory kit is the product of Triumph's use of proven engineering, exhaustive testing, and continuous striving for superior reliability, safety and performance.

Completely read all of these instructions before commencing the installation of the accessory kit in order to become thoroughly familiar with the kit's features and the installation process.

These instructions should be considered a permanent part of your accessory kit, and should remain with it even if your accessory equipped motorcycle is subsequently sold.

**Parts Supplied: A9798025, A9790116**

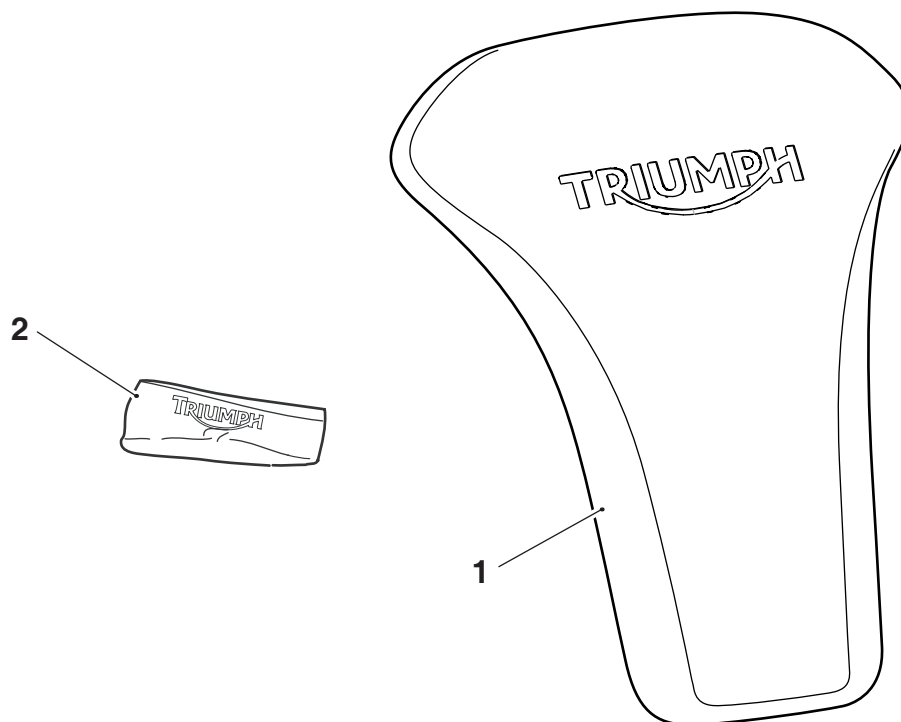

1. Tank pad	1 off	2. Cleaning wipe	1 off
-------------	-------	------------------	-------

---

Parts Supplied: A9790094

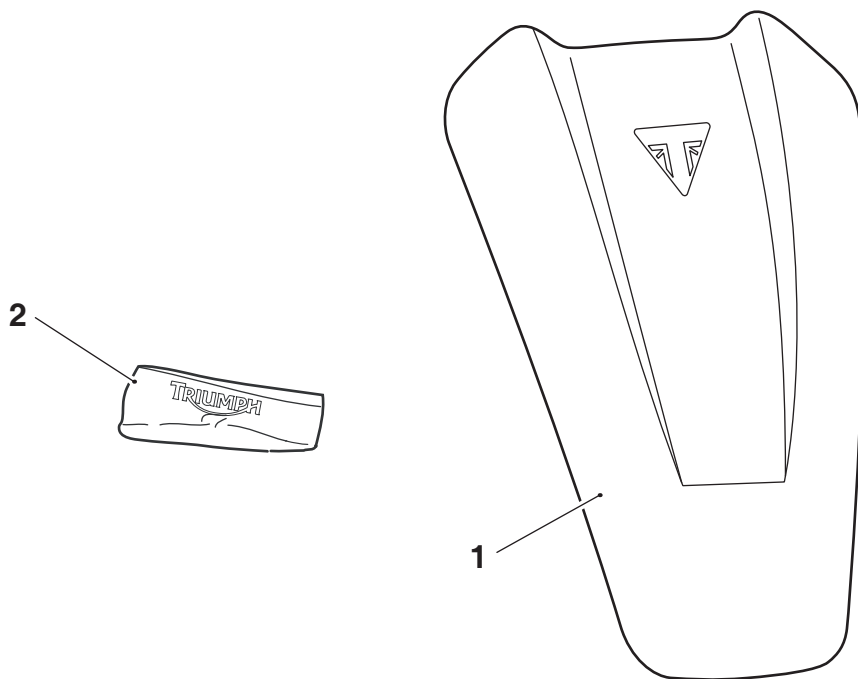

1. Tank pad	1 off	2. Cleaning wipe	1 off
-------------	-------	------------------	-------

Parts Supplied: A9798051

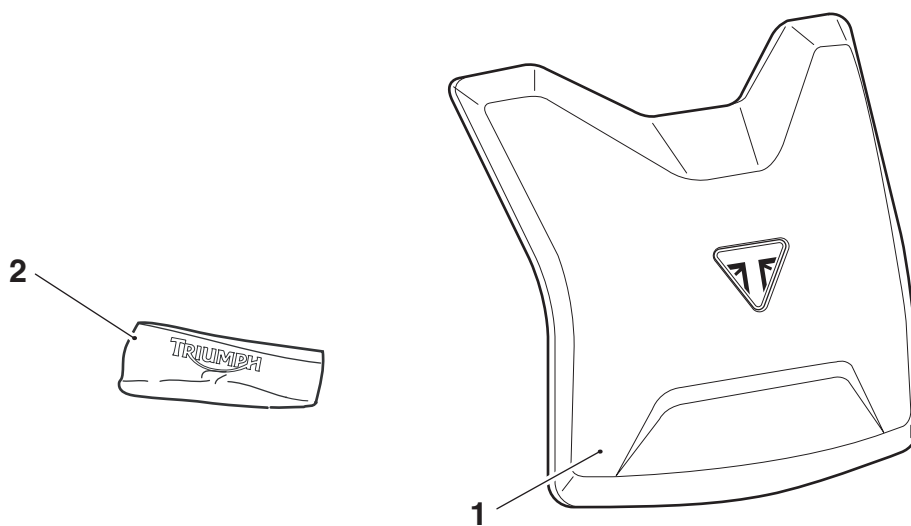

1. Tank pad	1 off	2. Cleaning wipe	1 off
-------------	-------	------------------	-------

### **Warning**

Fit only genuine Triumph accessories to those models approved by Triumph as listed in the associated Triumph fitting instructions. The accessory kits covered in this instruction are designed for use on specific models of Triumph motorcycle. The accessory kits and the models applicable are listed at the start of the instruction. They should never be fitted to any other Triumph model or to any other manufacturer's motorcycle. Fitting an accessory kit to a Triumph model not listed, or to any other manufacturer's motorcycle will affect the performance, stability and handling of the motorcycle. This may affect the rider's ability to control the motorcycle and could result in an accident causing severe injuries or death.

### **Warning**

Always have Triumph approved parts, accessories and conversions fitted by a trained technician of an authorised Triumph dealer. The fitment of parts, accessories and conversions by a technician who is not of an authorised Triumph dealer may affect the handling, stability or other aspects of the motorcycle's operation which may result in loss of motorcycle control and an accident.

### **Warning**

Make sure the motorcycle is supported. A correctly supported motorcycle will help prevent it from falling. An unstable motorcycle may fall, causing injury to the operator or damage to the motorcycle.

#### **Note:**

- **Triumph offers a broad range of approved genuine accessories for your motorcycle. We cannot therefore cover all possible equipment variations in these instructions. For removal and installation of Triumph Genuine Accessories, always refer to the instructions supplied with the respective accessory kit. To obtain additional copies of any Triumph accessory instructions, visit [www.triumphinstructions.com](http://www.triumphinstructions.com) or contact your authorised Triumph dealer.**

#### **Note:**

- **Once the tank pad has been fitted, it will become an integral part of the fuel tank and cannot be removed.**

#### **Note:**

- **Read the warning notices printed on the cleaning wipe packet in the fitting kit.**
  - **The surface to which the tank pad is affixed must be clean and dry to make sure that the adhesive has a sound base to adhere to. Use the cleaning wipe supplied for this purpose.**
  - **The ideal adhesive application temperature is 60°F (15.6°C) to 100°F (38°C)**
1. Using the cleaning wipe provided, clean the top surface of the fuel tank.

### **Caution**

When fitting self-adhesive parts, care must be taken to make sure positioning is correct and accurate. Once the adhesive has been attached to the mounting surface, there is no satisfactory method of removal and repositioning if incorrectly aligned. Initial bonding is instant, full bonding is achieved after 72 hours.

#### **Note:**

- **When positioning the tank pad make sure it is located centrally on the fuel tank.**

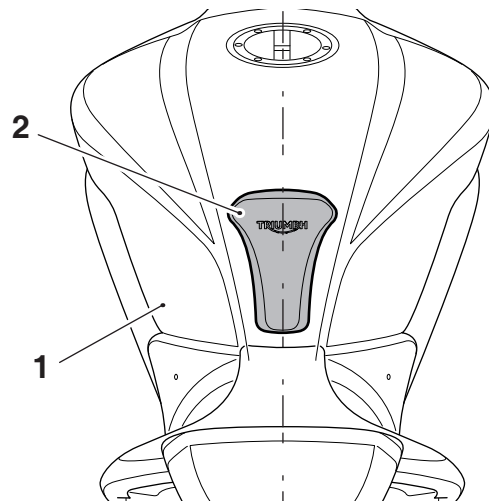

1. Fuel tank
  2. Tank pad (Speed Triple S shown)
2. Peel away the adhesive backing strips from the tank pad.

### Speed Triple S, Speed Triple R, Speed Triple RS Only

- Carefully position the tank pad on the fuel tank with the lower edge of the tank pad between 11 mm and 17 mm from the top edge of the rider seat, as shown. Apply firm and even hand pressure across the whole tank pad surface for one minute to make sure a good bond is achieved.

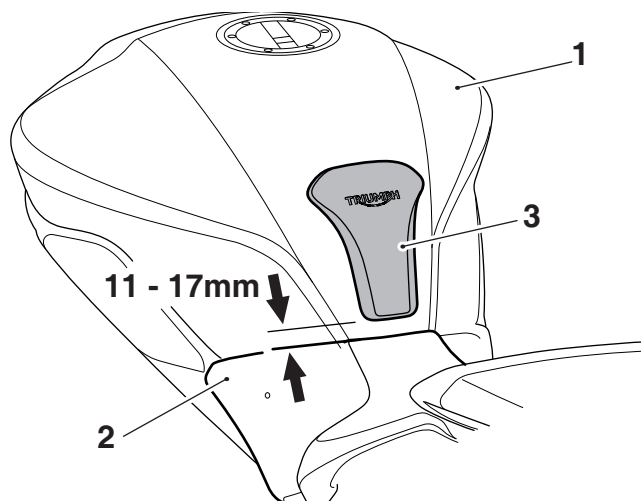

- Fuel tank
- Rider seat
- Tank pad

### Speed Triple 1200 RS, Speed Triple 1200 RR Only

- Carefully position the tank pad on the fuel tank with the lower edge of the tank pad between 25 mm and 31 mm from the top edge of the rider seat, as shown. Apply firm and even hand pressure across the whole tank pad surface for one minute to make sure a good bond is achieved.

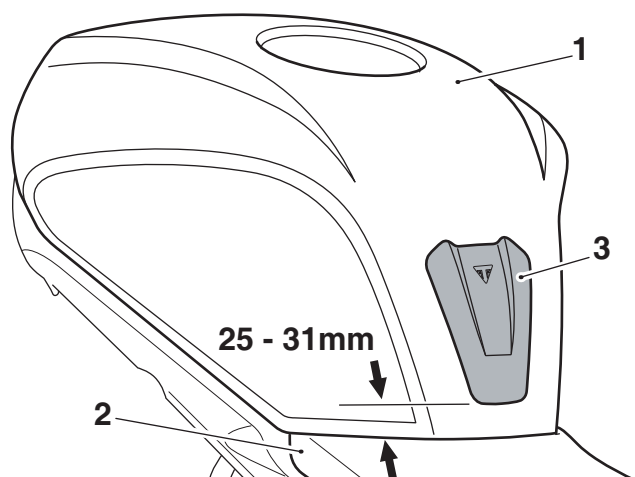

- Fuel tank
- Rider seat
- Tank pad

### Tiger 1200 Only

#### Note:

- The shape of the tank pad may prevent it from sticking to the fuel tank, if it is not correctly located. It is therefore recommended to offer up the tank pad to the fuel tank prior to removing the backing paper, to help find the correct position.

- Carefully position the tank pad on the fuel tank with the lower edge of the tank pad approximately 20 mm from the top edge of the rider seat, when set in its high position, as shown. Apply firm and even hand pressure across the whole tank pad surface for one minute to make sure a good bond is achieved.

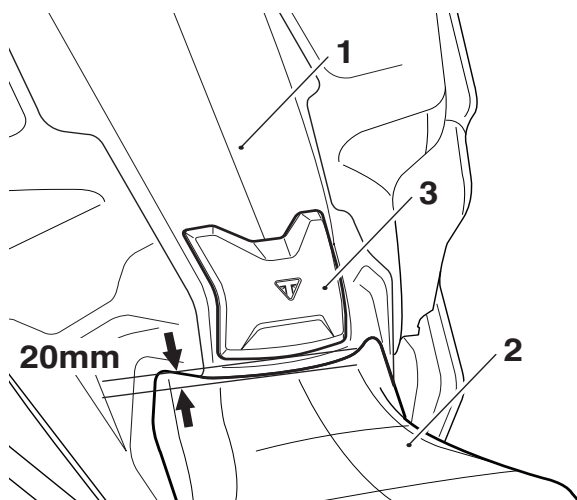

- Fuel tank
- Rider seat
- Tank pad



### Warning

If, after fitment of this accessory kit, you have any doubt about the performance of any aspect of the motorcycle, contact an authorised Triumph dealer and do not ride the motorcycle until the authorised dealer has declared it fit for use. Riding a motorcycle when there is any doubt as to any aspect of the performance of the motorcycle may result in loss of control of the motorcycle, leading to an accident.



### Warning

The motorcycle must not be operated above the legal road speed limit except in closed-course conditions.



### Warning

Only operate this Triumph motorcycle at high speed in closed-course, on-road competition or on closed-course racetracks. High-speed operation should only be attempted by riders who have been instructed in the techniques necessary for high-speed riding and are familiar with the motorcycle's characteristics in all conditions.

High-speed operation in any other circumstances is dangerous and will lead to loss of motorcycle control and an accident.