



Accessory Fitting Instructions

Thank you for choosing this Triumph genuine accessory kit. This accessory kit is the product of Triumph's use of proven engineering, exhaustive testing, and continuous striving for superior reliability, safety and performance.

Completely read all of these instructions before commencing the installation of the accessory kit in order to become thoroughly familiar with the kit's features and the installation process.

These instructions should be considered a permanent part of your accessory kit, and should remain with it even if your accessory equipped motorcycle is subsequently sold.

Frame Protectors Kit

Kit Number	Models
A9788070	Trident from VIN AC6898

⚠ WARNING

If the motorcycle is involved in an accident, collision or fall, it must be taken for inspection and repair. Inspections and repairs must be completed by a competent person with the specialist knowledge and technical understanding of motorcycles, such as an authorised Triumph dealer. Any accident can cause damage to the motorcycle that, if not correctly repaired, may cause a second accident which could result in serious injury or death.

NOTICE

Frame protectors are intended to protect the motorcycle in the event of a static drop only.

Parts supplied

NOTICE

The kit may include two M10 x 55 mm fixings, or one M10 x 55 mm fixing and one M10 x 45 mm fixing.

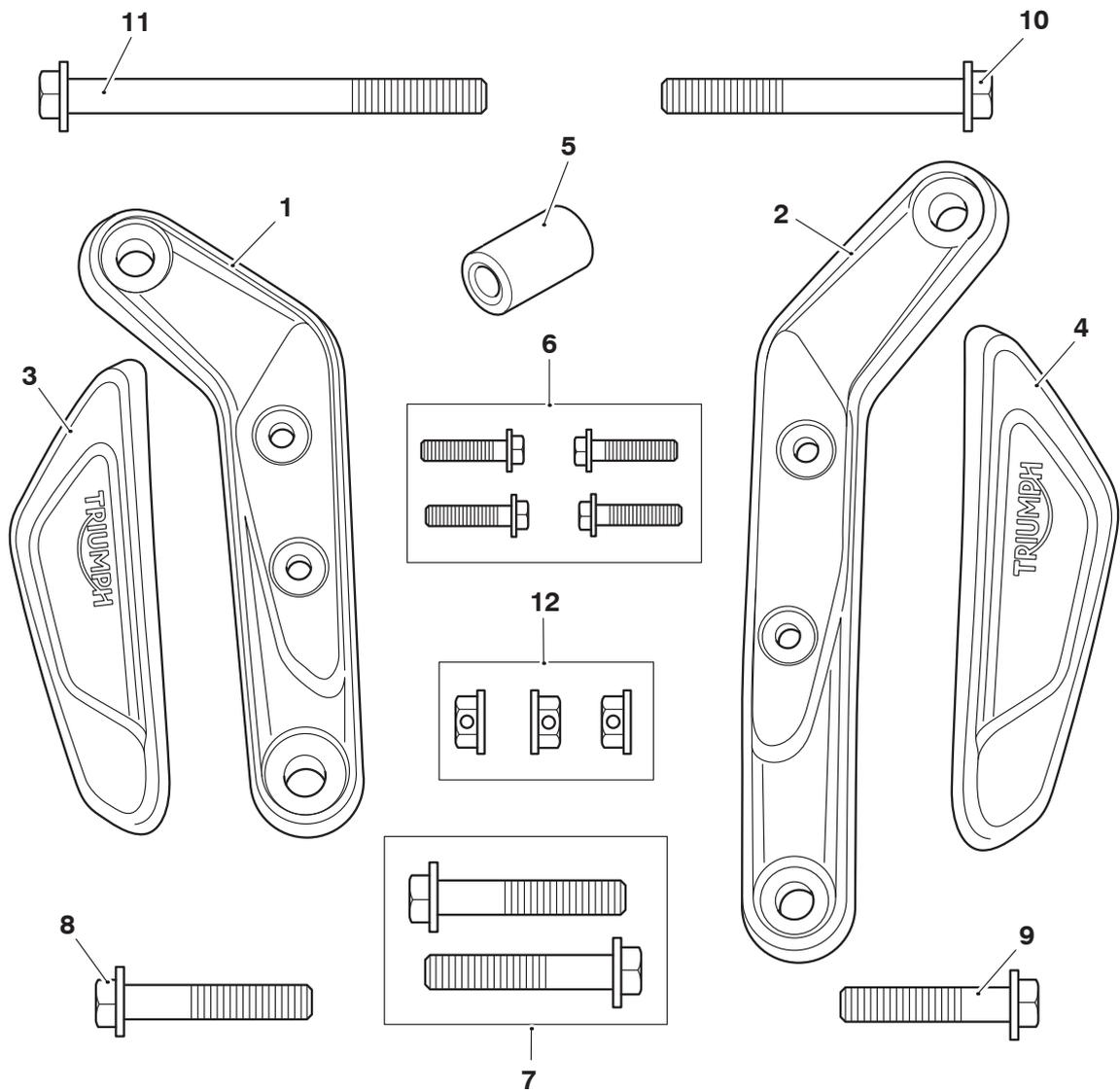

1. Support moulding, left hand	1 off	7. Fixing, M10 x 55 mm (where supplied)	2 off
2. Support moulding, right hand	1 off	8. Fixing, M10 x 55 mm (where supplied)	1 off
3. Cover moulding, left hand	1 off	9. Fixing, M10 x 45 mm (where supplied)	1 off
4. Cover moulding, right hand	1 off	10. Fixing, M10 x 90 mm	1 off
5. Spacer	1 off	11. Fixing M10 x 130 mm	1 off
6. Fixing, M6 x 25 mm	4 off	12. Lock nut, M10	3 off

⚠ WARNING

Fit only genuine Triumph accessories to those models approved by Triumph as listed in the associated Triumph fitting instructions.

The accessory kits covered in this instruction are designed for use on specific models of Triumph motorcycle. The accessory kits and the models applicable are listed at the start of the instruction. They should never be fitted to any other Triumph model or to any other manufacturer's motorcycle.

Fitting an accessory kit to a Triumph model not listed, or to any other manufacturer's motorcycle, will affect the performance, stability and handling of the motorcycle.

Failure to follow the advice above may lead to loss of motorcycle control which could result in serious injury or death.

⚠ WARNING

Always have Triumph approved parts, accessories and conversions fitted by a competent person with the specialist knowledge and technical understanding of motorcycles, such as an authorised Triumph dealer.

The fitment of parts, accessories and conversions by a person without the specialist knowledge and technical understanding of motorcycles may affect the handling, stability or other aspects of the motorcycle's operation.

Failure to follow the advice above may lead to loss of motorcycle control which could result in serious injury or death.

⚠ WARNING

A torque wrench of known accurate calibration must be used when fitting this accessory kit.

Failure to tighten any of the fasteners to the correct torque specification may affect motorcycle performance, handling and stability.

Failure to follow the advice above may lead to loss of motorcycle control which could result in serious injury or death.

⚠ WARNING

Make sure the motorcycle is stabilised and adequately supported.

Do not support the motorcycle on any ancillary component, the exhaust system or any other non structural parts of the motorcycle frame.

A correctly supported motorcycle will help prevent it from falling.

An unstable motorcycle may fall resulting in motorcycle damage, serious injury or death.

NOTICE

Triumph offers a broad range of approved genuine accessories for your motorcycle.

We cannot therefore cover all possible equipment variations in these instructions. For removal and installation of Triumph Genuine Accessories, always refer to the instructions supplied with the respective accessory kit.

To obtain additional copies of any Triumph accessory instructions, visit www.triumphinstructions.com or contact your authorised Triumph dealer.

⚠ CAUTION

If the engine has recently been running, the exhaust components may be hot to the touch.

To avoid skin damage, always allow the hot parts to cool before touching the exhaust system.

Contact with the hot components may cause minor to moderate injury to exposed skin.

1. Collect the right hand support moulding, right hand cover moulding and two M6 x 25 mm fixings from the kit.
2. Position the cover moulding onto the support moulding in the orientation shown. Fit the M6 x 25 mm fixings and tighten to 9 Nm.

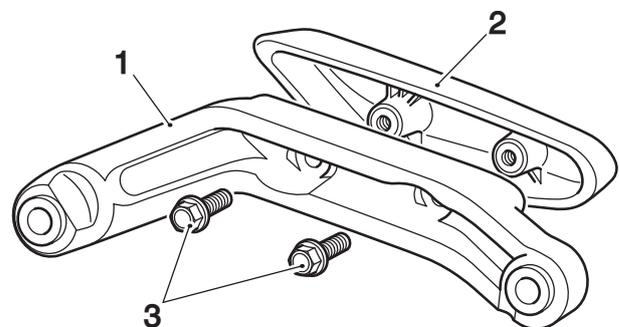

1. Support moulding
2. Cover moulding
3. Fixings, M6 x 25 mm

3. Repeat steps 1 and 2 for the left hand support and cover mouldings.

- Remove the lower radiator bracket fixing. Retain the fixing for reuse.

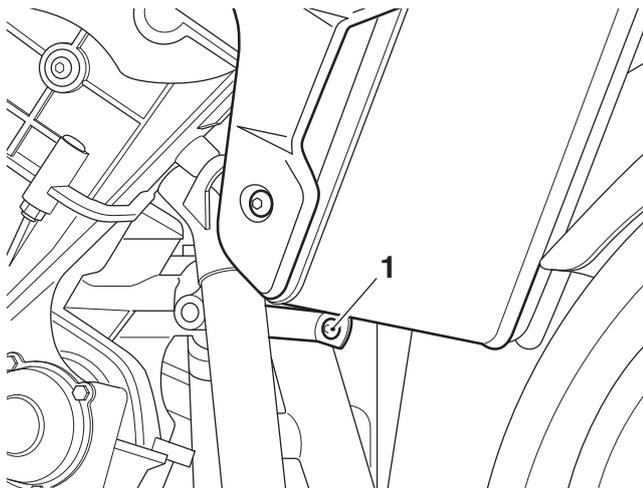

1. Lower radiator bracket fixing

NOTICE

Remove the engine mounting fixings in the sequence detailed in this document only.

Do not remove the left hand and right hand engine mounting fixings at the same time.

This could result in the engine moving within the frame and misalignment of the engine mounting positions, preventing fitment of the new fixings.

Right Hand Side

- Carefully rotate the radiator forwards to allow access to the front top engine mounting lock nut. Remove the two top engine mounting fixings. Retain the fixings and lock nuts for use if the motorcycle is returned to its original condition.

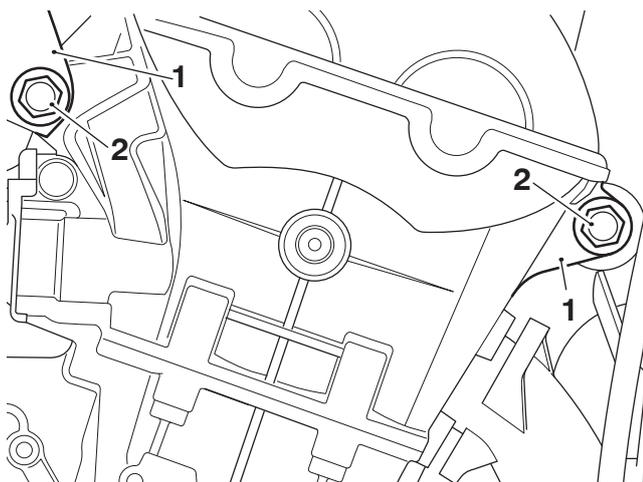

1. Top engine mountings
2. Fixings

NOTICE

The kit may include one M10 x 55 mm fixing and one M10 x 45 mm fixing, the M10 x 55 mm fixing should be fitted at this position.

- Fit the right hand frame protector assembly to the top rear engine mounting point, in the orientation shown and loosely fit an M10 x 55 mm fixing and M10 lock nut from the kit.

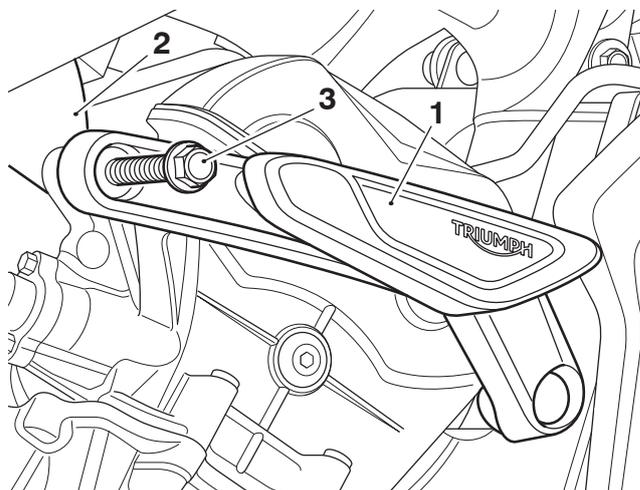

1. Frame protector assembly, right hand
2. Top rear engine mounting
3. Fixing, M10 x 55 mm

- Rotate the frame protector assembly to align with the top front engine mounting position. Carefully rotating the radiator forwards to allow access, loosely fit the M10 x 90 mm fixing and M10 lock nut from the kit.

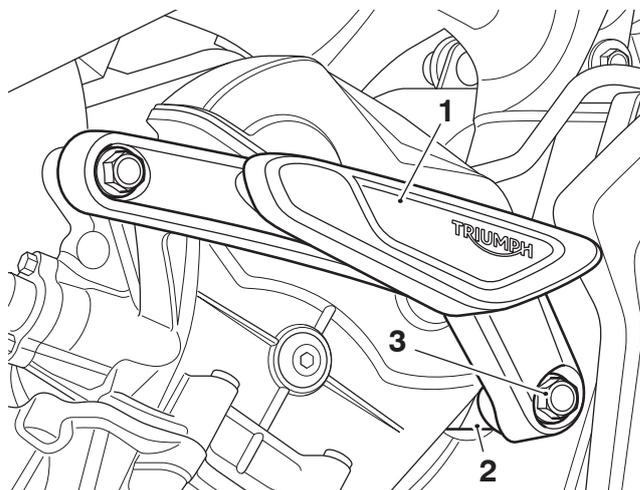

1. Frame protector, right hand
2. Top front engine mounting
3. Fixing, M10 x 90 mm

- Tighten both frame protector fixings to 48 Nm.

Left Hand Side

- Carefully rotate the radiator forwards to allow access to the front top engine mounting fixing lock nut. Remove the two top engine mounting fixings. Retain the fixings and lock nut for use if the motorcycle is returned to its original condition.

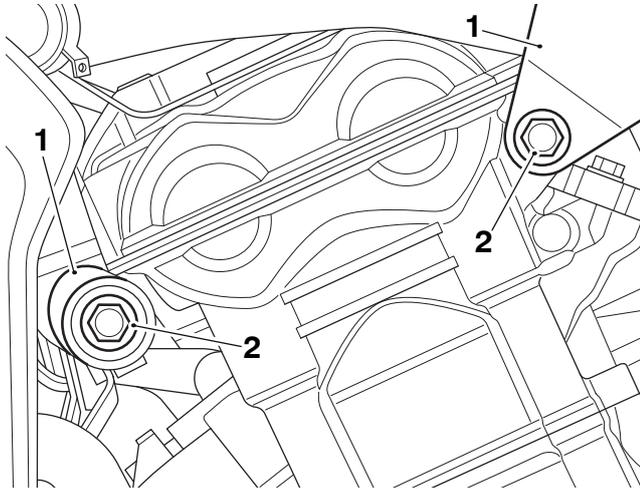

- Top engine mountings
- Fixings

- Fit the spacer from the kit into the recess in the motorcycle frame at the top front engine mounting position. Fit the left hand frame protector assembly to the top front engine mounting in the orientation shown. Carefully rotating the radiator forwards to allow access, loosely fit the M10 x 130 mm fixing and M10 lock nut from the kit.

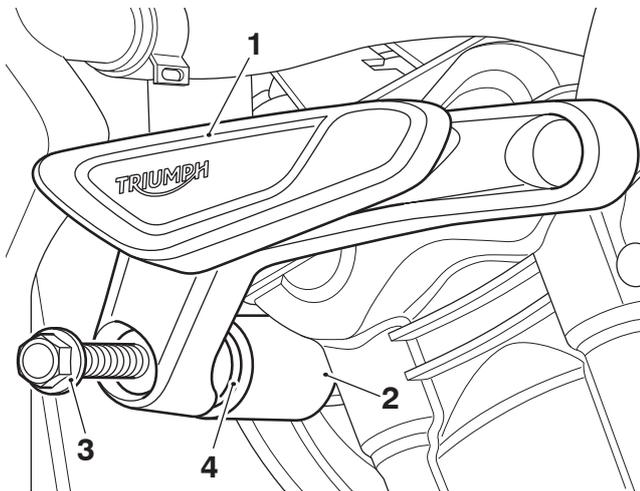

- Frame protector assembly, left hand
- Top front engine mounting
- Fixing, M10 x 130 mm
- Spacer

NOTICE

The kit may include two M10 x 55 mm fixings, or one M10 x 55 mm fixing and one M10 x 45 mm fixing. If the kit contains an M10 x 45 mm fixing it should be fitted at this position.

- Lubricate the threads of the mounting bolt with a smear of proprietary high temperature copper based grease.
- Rotate the frame protector assembly to align with the top rear engine mounting position and loosely fit an M10 x 55 mm, or where included M10 x 45 mm fixing from the kit.

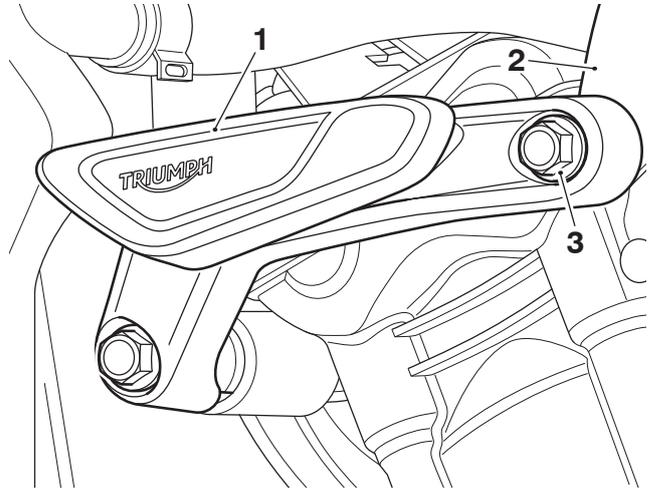

- Frame protector assembly, left hand
- Top rear engine mounting
- Fixing, M10 x 55 mm or M10 x 45 mm

- Tighten both frame protector fixings to 48 Nm.
- Refit the lower radiator bracket fixing and tighten to 6 Nm.

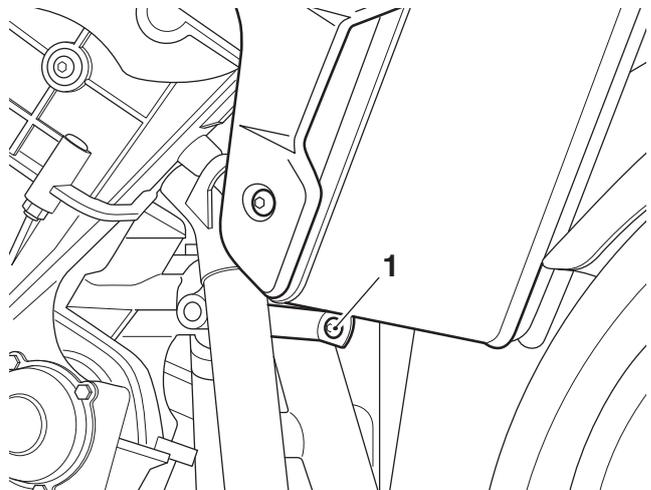

- Lower radiator bracket fixing

⚠ WARNING

After fitting the accessory kit the motorcycle will exhibit new handling characteristics.

Operate the motorcycle in a safe area free from traffic to gain familiarity with any new characteristics.

Operation of the motorcycle when not familiar with any new handling characteristics may lead to loss of motorcycle control which could result in serious injury or death.

⚠ WARNING

If, after fitting this accessory kit, you have any doubt about the performance of any aspect of the motorcycle, contact a competent person with the specialist knowledge and technical understanding of motorcycles, such as an authorised Triumph dealer.

Riding a motorcycle when there is any doubt as to any aspect of the performance of the motorcycle may lead to loss of motorcycle control which could result in serious injury or death.

⚠ WARNING

Never ride an accessory-equipped motorcycle at speeds above 80 mph (130 km/h).

Remember that the 80 mph (130 km/h) limit will be reduced by the fitting of non-approved accessories, incorrect loading, worn tyres, overall motorcycle condition and poor road or weather conditions.

The presence of accessories will cause changes in the stability and handling of the motorcycle. Failure to allow for changes in motorcycle stability may lead to loss of motorcycle control which could result in serious injury or death.

⚠ WARNING

High-speed operation should only be attempted by riders who have been instructed in the techniques necessary for high-speed riding and are familiar with the motorcycle's characteristics in all conditions.

Only operate this Triumph motorcycle at high speed in closed-course, on-road competition or on closed-course racetracks.

High-speed operation in any other circumstances is dangerous and may lead to loss of motorcycle control which could result in serious injury or death.

NOTICE

The motorcycle must not be operated above the legal road speed limit except in closed-course conditions.