

Fitting Instructions:

Speed Triple from VIN 461332, Speed Triple S, Speed Triple R, Speed Triple RS A9758126, A9758293

Thank you for choosing this Triumph genuine accessory kit. This accessory kit is the product of Triumph's use of proven engineering, exhaustive testing, and continuous striving for superior reliability, safety and performance.

Completely read all of these instructions before commencing the installation of the accessory kit in order to become thoroughly familiar with the kit's features and the installation process.

These instructions should be considered a permanent part of your accessory kit, and should remain with it even if your accessory-equipped motorcycle is subsequently sold.

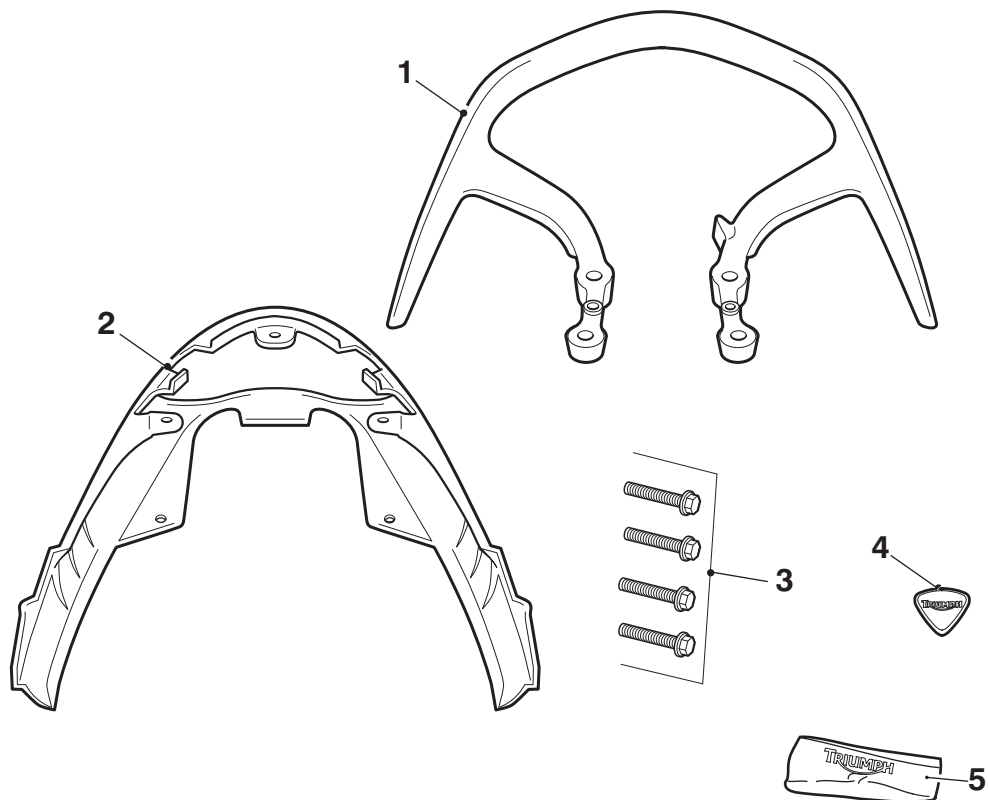

T0834

Parts Supplied:

1. Grab rail	1 off	4. Badge (adhesive)	1 off
2. Rear light moulding	1 off	5. Cleaning wipe	1 off
3. Screw	4 off		



Warning

The accessory kits covered in this instruction are designed for use on specific models of Triumph motorcycle. The accessory kits and the models applicable are listed at the start of the instruction. They should not be fitted to any other Triumph model or to any other manufacturer's motorcycle. Fitting an accessory kit to a Triumph model not listed, or to any other manufacturer's motorcycle will affect the performance, stability and handling of the motorcycle. This may affect the rider's ability to control the motorcycle and could cause an accident.



Warning

Always have Triumph approved parts, accessories and conversions fitted by a trained technician of an authorised Triumph dealer. The fitment of parts, accessories and conversions by a technician who is not of an authorised Triumph dealer may affect the handling, stability or other aspects of the motorcycle's operation which may result in loss of motorcycle control and an accident.



Warning

Throughout this operation, ensure that the motorcycle is stabilised and adequately supported to prevent risk of injury from the motorcycle falling.



Warning

A torque wrench of known accurate calibration must be used when fitting this accessory kit. Failure to tighten any of the fasteners to the correct torque specification may result in loss of motorcycle control and an accident.

1. Position the motorcycle on a paddock stand.



Caution

When fitting self-adhesive parts care must be taken to ensure positioning is correct and accurate. Once the adhesive has been attached to the mounting surface, there is no satisfactory method of removal or re-positioning if incorrectly aligned. Initial bonding is instant, full bonding is achieved after 72 hours.

Note:

- **Read the warning notices printed on the cleaning wipe packet.**
 - **The surface to which the badge is affixed must be clean and dry to ensure that the adhesive has a sound base to adhere to. Use the cleaning wipe supplied for this purpose.**
2. Peel off the backing strip from the adhesive badge.
 3. Using the cleaning wipe provided, clean the area of the grab rail as shown below.

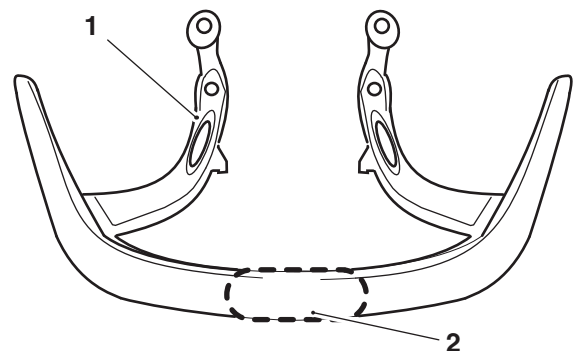

1. Grab rail
2. Cleaning area

- Position the badge centrally on the upper surface of the grab rail. Apply firm and even pressure to ensure a good bond is achieved.

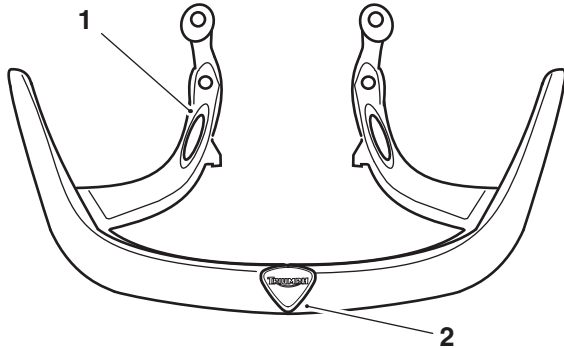

- Grab rail
- Badge

- Remove the seat as described in the Service Manual.
- Remove the rear side panels, as described in the Service Manual.
- Remove the rear light moulding, as described in the Service Manual.

Note:

- Note the orientation of the grommets in the rear light moulding for installation.**
- Remove the grommets from the rear light moulding. Retain the grommets for reuse. Retain the rear light moulding if the motorcycle is to be returned to its original condition.

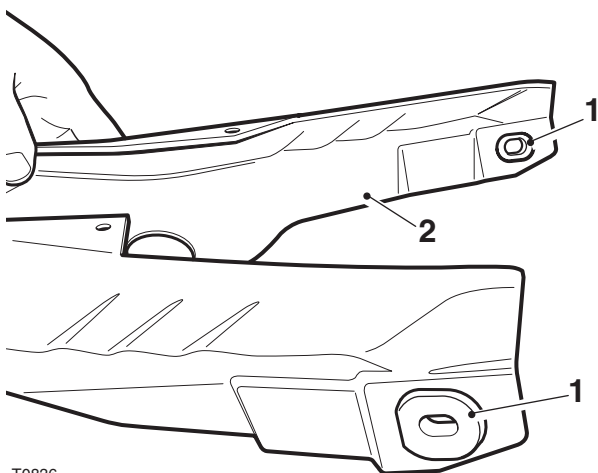

T0836

- Grommets
- Rear light moulding

- Fit the grommets to the rear light moulding from the kit as noted for removal.
- Fit the rear light moulding to the motorcycle, as described in the Service Manual.

- Check that the stand off rubbers between the rear light moulding and the subframe are fully located onto their locating tangs.

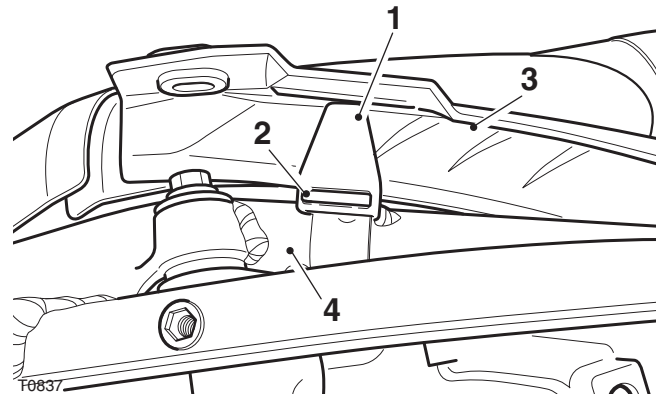

- Stand off rubber (right hand side shown)
- Locating tang
- Rear light moulding
- Subframe

- Align the grab rail to the subframe, fit the bolts and tighten to 27 Nm.

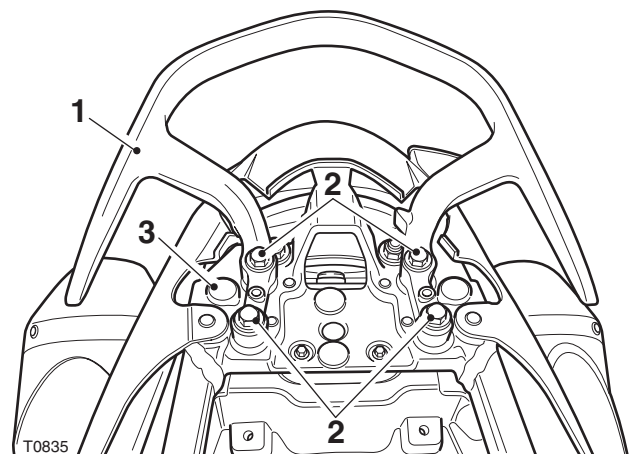

- Grab rail
- Bolts
- Subframe

- Refit the rear side panels, as described in the Service Manual.
- Refit the seat, as described in the Service Manual.
- Remove the motorcycle from the paddock stand.



Warning

After fitting the accessory kit the motorcycle will exhibit new handling characteristics. Operate the motorcycle in a safe area free from traffic to gain familiarity with any new characteristics. Operation of the motorcycle when not familiar with any new handling characteristics may result in loss of motorcycle control and an accident.



Warning

If, after fitment of this accessory kit, you have any doubt about the performance of any aspect of the motorcycle, contact an authorised Triumph dealer and do not ride the motorcycle until the authorised dealer has declared it fit for use. Riding a motorcycle when there is any doubt as to any aspect of the performance of the motorcycle may result in loss of control of the motorcycle leading to an accident.



Warning

Never ride an accessory equipped motorcycle at speeds above 80 mph (130 km/h). The presence of accessories will cause changes in the stability and handling of the motorcycle. Failure to allow for changes in motorcycle stability may lead to loss of control or an accident. Remember that the 80 mph (130 km/h) limit will be reduced by the fitting of non-approved accessories, incorrect loading, worn tyres, overall motorcycle condition and poor road or weather conditions.



Warning

The motorcycle must not be operated above the legal road speed limit except in closed-course conditions.



Warning

Only operate this Triumph motorcycle at high speed in closed-course, on-road competition or on closed-course race tracks. High-speed operation should only be attempted by riders who have been instructed in the techniques necessary for high-speed riding and are familiar with the motorcycle's characteristics in all conditions. High-speed operation in any other circumstances is dangerous and will lead to loss of motorcycle control and an accident.