



Accessory Fitting Instructions

| Flyscreen Visor Kit | |
|---------------------|---|
| Kit number | Models Affected |
| A9708420 | Street Triple S and Street Triple S 660cc |

Thank you for choosing this Triumph genuine accessory kit. This accessory kit is the product of Triumph's use of proven engineering, exhaustive testing, and continuous striving for superior reliability, safety and performance.

Completely read all of these instructions before commencing the installation of the accessory kit in order to become thoroughly familiar with the kit's features and the installation process.

These instructions should be considered a permanent part of your accessory kit, and should remain with it even if your accessory equipped motorcycle is subsequently sold.

Parts supplied:

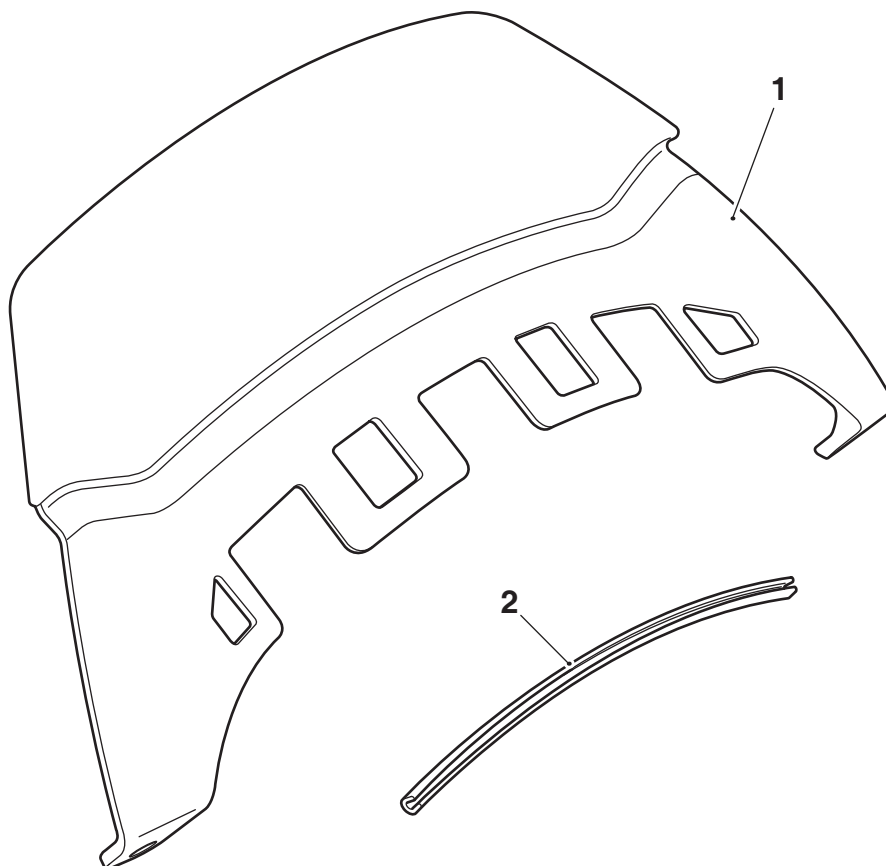

| | | | |
|--------------------|-------|----------------|-------|
| 1. Flyscreen visor | 1 off | 2. Rubber trim | 1 off |
|--------------------|-------|----------------|-------|

Warning

The accessory kits covered in this instruction are designed for use on specific models of Triumph motorcycle. The accessory kits and the models applicable are listed at the start of the instruction. They should not be fitted to any other Triumph model or to any other manufacturer's motorcycle. Fitting an accessory kit to a Triumph model not listed, or to any other manufacturer's motorcycle will affect the performance, stability and handling of the motorcycle. This may affect the rider's ability to control the motorcycle and could cause an accident.

Warning

Always have Triumph approved parts, accessories and conversions fitted by a trained technician of an authorised Triumph dealer. The fitment of parts, accessories and conversions by a technician who is not of an authorised Triumph dealer may affect the handling, stability or other aspects of the motorcycle's operation which may result in loss of motorcycle control and an accident.

Warning

Throughout this operation, ensure that the motorcycle is stabilised and adequately supported to prevent risk of injury from the motorcycle falling.

Warning

A torque wrench of known accurate calibration must be used when fitting this accessory kit. Failure to tighten any of the fasteners to the correct torque specification may affect motorcycle performance, handling and stability. This may result in loss of motorcycle control and an accident.

Note:

- Triumph offers a broad range of approved genuine accessories for your motorcycle. We cannot therefore cover all possible equipment variations in these instructions. For removal and installation of Triumph Genuine Accessories, always refer to the instructions supplied with the respective accessory kit. To obtain additional copies of any Triumph accessory instructions, visit www.triumphinstructions.com or contact your authorised Triumph dealer.

- Remove the flyscreen as described in the Service Manual. Retain the flyscreen fixings for reuse.
- Remove the two fixings securing the flyscreen infill panel and remove the infill panel. Retain the fixings for reuse. Retain the infill panel for reuse if the motorcycle is to be returned to its original condition.

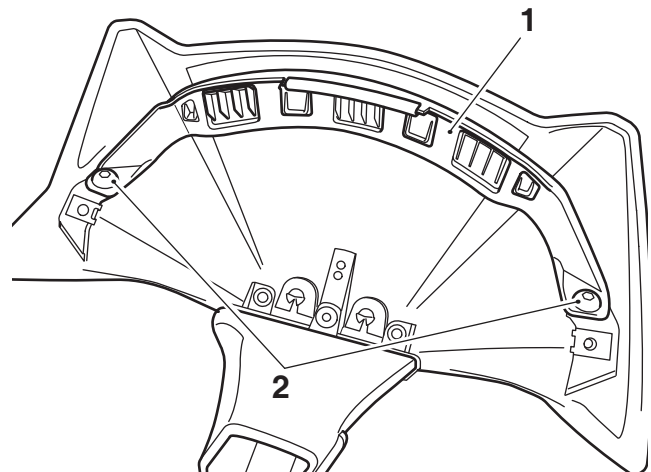

1. Flyscreen infill panel
2. Fixings

3. Fit the rubber trim from the kit onto the rear of the flyscreen visor, as shown.

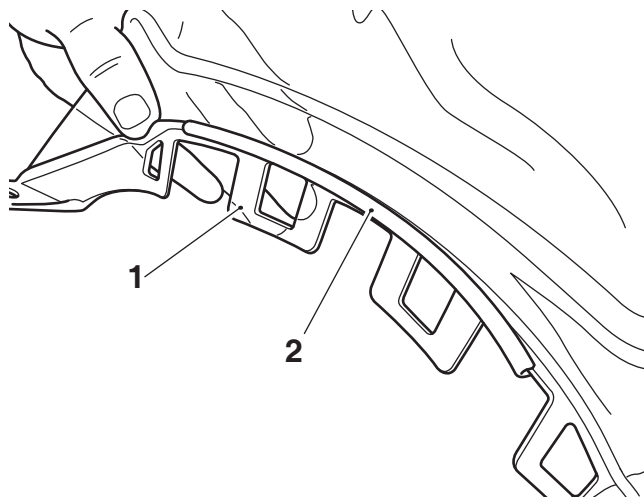

1. Flyscreen visor
2. Rubber trim

4. Position the flyscreen visor on the rear of the flyscreen ensuring it locates correctly behind the three mouldings on the flyscreen as shown. Press the flyscreen visor over the retaining tabs to attach the flyscreen visor to the flyscreen.

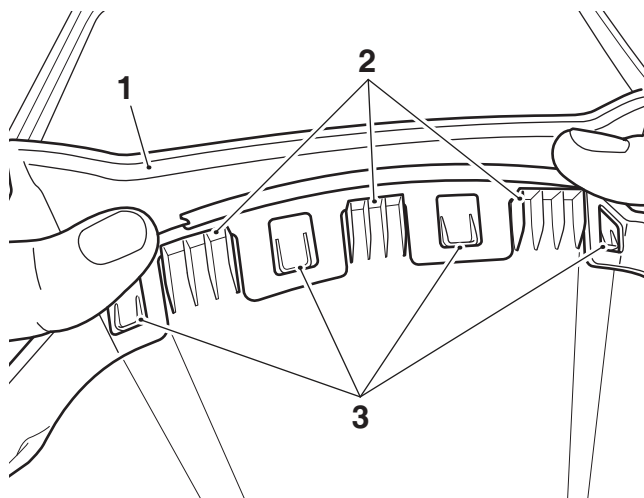

1. Flyscreen visor
2. Flyscreen mouldings
3. Location tabs

5. Fit the two original fixings to secure the flyscreen visor to the flyscreen. Tighten the fixings to **3 Nm**.

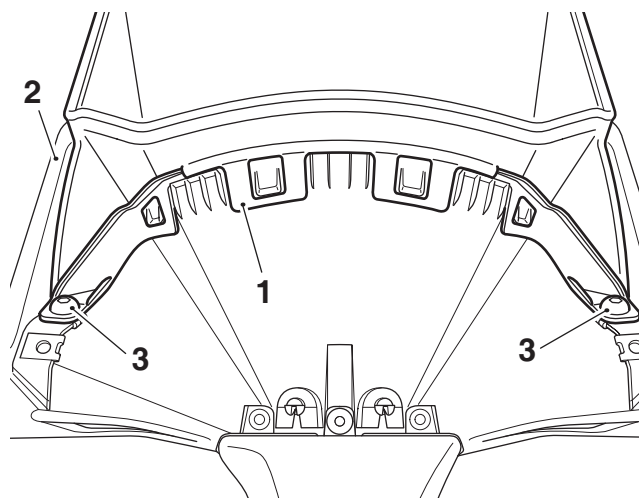

1. Flyscreen visor
2. Flyscreen
3. Fixings

6. Refit the flyscreen using the original fixings, as described in the Service Manual.

 **Warning**

After fitting the accessory kit the motorcycle will exhibit new handling characteristics. Operate the motorcycle in a safe area free from traffic to gain familiarity with any new characteristics. Operation of the motorcycle when not familiar with any new handling characteristics may result in loss of motorcycle control and an accident.

 **Warning**

If, after fitment of this accessory kit, you have any doubt about the performance of any aspect of the motorcycle, contact an authorised Triumph dealer and do not ride the motorcycle until the authorised dealer has declared it fit for use. Riding a motorcycle when there is any doubt as to any aspect of the performance of the motorcycle may result in loss of control of the motorcycle leading to an accident.

 **Warning**

Never attempt to clean the flyscreen visor while riding the motorcycle. Removal of the rider's hands from the handlebars while riding the motorcycle will diminish the ability of the rider to maintain control of the motorcycle. Attempting to clean the flyscreen visor while riding the motorcycle may result in loss of control of the motorcycle and an accident.

 **Warning**

The flyscreen visor is not a substitute for a safety helmet or eye protection. Sports screens are designed to provide wind protection and increased riding comfort. They are not designed to provide protection in the event of a collision with another vehicle, the road, birds or any other object. When riding a motorcycle both rider and passenger must always wear a safety helmet, eye protection, gloves and trousers (close fitting around the knees and ankle). Although full protection is not possible, wearing the correct protective clothing can reduce the risk of injury when riding.

 **Warning**

Never ride an accessory-equipped motorcycle at speeds above 80 mph (130 km/h).

The presence of accessories will cause changes in the stability and handling of the motorcycle. Failure to allow for changes in motorcycle stability may lead to loss of control or an accident.

Remember that the 80 mph (130 km/h) limit will be reduced by the fitting of non-approved accessories, incorrect loading, worn tyres, overall motorcycle condition and poor road or weather conditions.

 **Warning**

The motorcycle must not be operated above the legal road speed limit except in closed-course conditions.

 **Warning**

Only operate this Triumph motorcycle at high speed in closed-course, on-road competition or on closed-course racetracks. High-speed operation should only be attempted by riders who have been instructed in the techniques necessary for high-speed riding and are familiar with the motorcycle's characteristics in all conditions.

High-speed operation in any other circumstances is dangerous and will lead to loss of motorcycle control and an accident.