

Fitting Instructions:
Thunderbird and Thunderbird Storm
A9748076 or A9700367

Thank you for choosing this Triumph genuine accessory kit. This accessory kit is the product of Triumph's use of proven engineering, exhaustive testing, and continuous striving for superior reliability, safety and performance.

Completely read all of these instructions before commencing the installation of the accessory kit in order to become thoroughly familiar with the kit's features and the installation process.

These instructions should be considered a permanent part of your accessory kit, and should remain with it even if your accessory equipped motorcycle is subsequently sold.

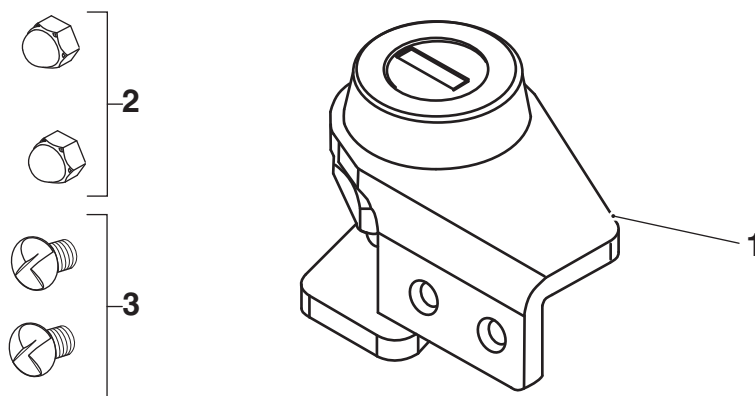

Parts Supplied A9748076:

1. Lock assembly	1 off	3. Bolt, M5 x 20 mm	2 off
2. Dome nut	2 off		

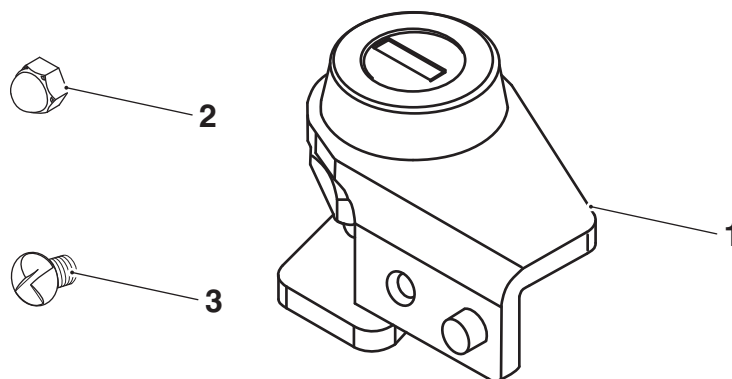

Parts Supplied A9700367:

1. Lock assembly	1 off	3. Bolt, M5 x 20 mm	1 off
2. Dome nut	1 off		



Warning

This accessory kit is designed for use on Triumph Thunderbird and Thunderbird Storm motorcycles only and should not be fitted to any other Triumph model or to any other manufacturer's motorcycle. Fitting this accessory kit to any other Triumph model, or to any other manufacturer's motorcycle, may interfere with the rider and could affect the handling, stability or other aspects of the motorcycle's operation which may result in loss of motorcycle control and an accident.



Warning

Always have Triumph approved parts, accessories and conversions fitted by a trained technician of an authorised Triumph dealer. The fitment of parts, accessories and conversions by a technician who is not of an authorised Triumph dealer may affect the handling, stability or other aspects of the motorcycle's operation which may result in loss of motorcycle control and an accident.



Warning

Throughout this operation, ensure that the motorcycle is stabilised and adequately supported on a paddock stand to prevent risk of injury from the motorcycle falling.



Warning

A torque wrench of known accurate calibration must be used when fitting this accessory kit. Failure to tighten any of the fasteners to the correct torque specification may affect motorcycle performance, handling and stability. This may result in loss of motorcycle control and an accident.

Note:

- **Before fitting this accessory kit, ensure the owner of the motorcycle has been informed of the warnings contained in these instructions.**

1. Align the lock to the fixing holes in the right hand bracket.

Thunderbird only

2. Fit the bolts through the bracket on the lock and the windscreen bracket. Fit the dome nuts but do not fully tighten at this stage.

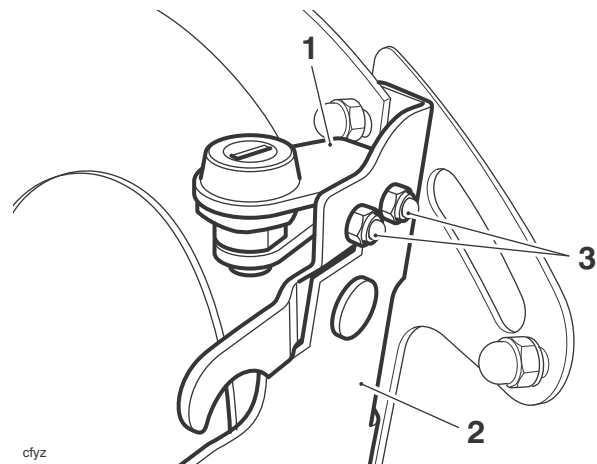

1. Windscreen lock
2. Windscreen bracket
3. Dome nuts

3. To ensure a smooth operation of the lock, insert the key and turn clockwise to the locked position.

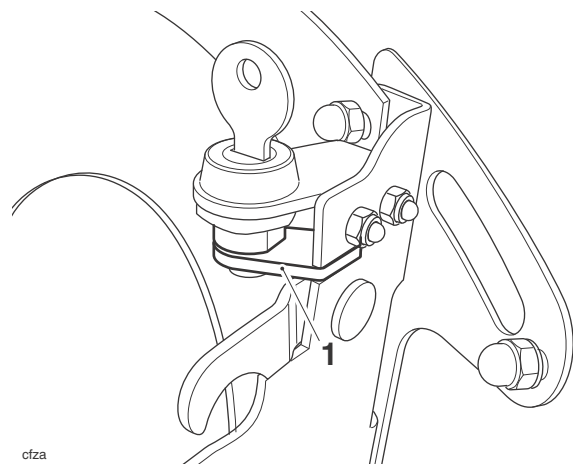

1. Locked position

- Check the operation of the lock by unlocking and locking. Adjust the position of the lock if necessary.

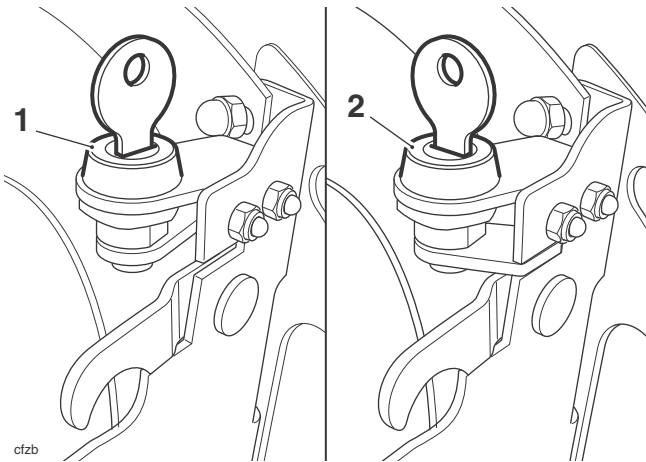

- Unlocked**
- Locked**

- Tighten the dome nuts to **4 Nm**.

Thunderbird Storm only

- Align the dowel on the lock bracket to the front hole of the windscreen bracket.
- Fit the bolt through the rear hole of the windscreen bracket. Fit the dome nut but do not fully tighten at this stage.

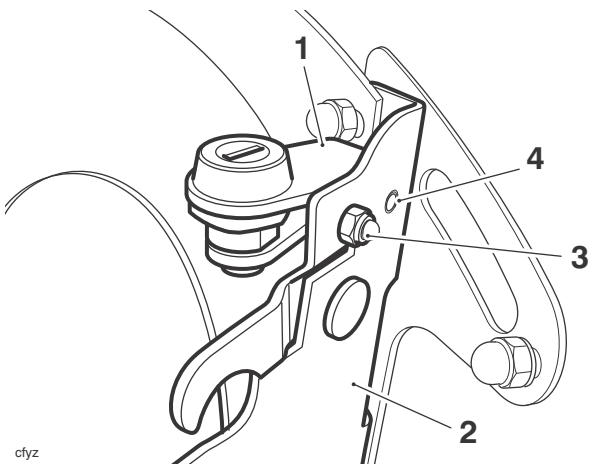

- Windscreen lock**
- Windscreen bracket**
- Dome nut**
- Dowel**

- To ensure a smooth operation of the lock, insert the key and turn clockwise to the locked position.

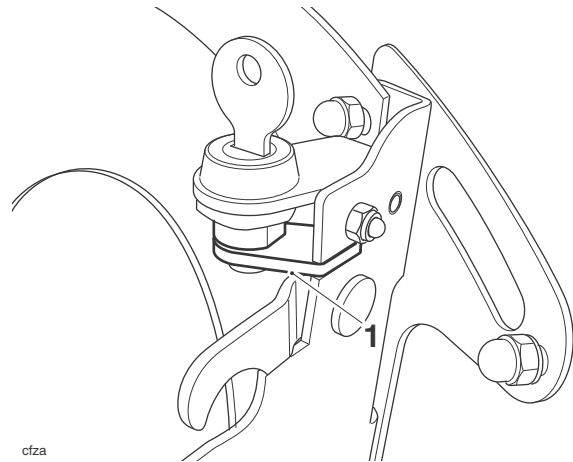

- Locked position**

- Check the operation of the lock by unlocking and locking. Adjust the position of the lock if necessary.

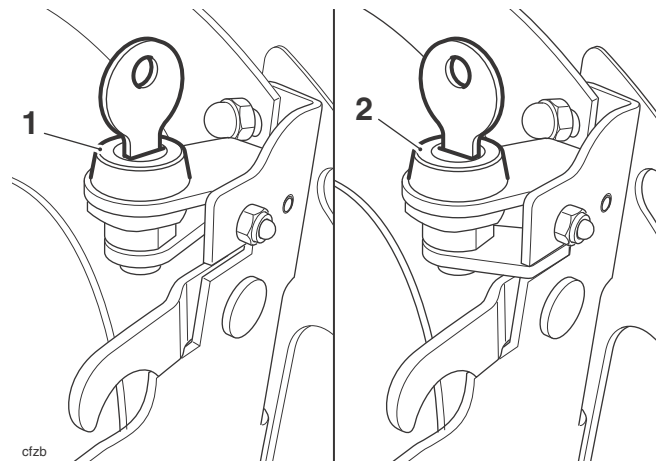

- Unlocked**
- Locked**

- Tighten the dome nut to **4 Nm**.

All Models

- Turn the windscreen lock to the unlocked position and remove the key.

Installing the Windscreen

1. Stand astride the front wheel and align the windscreen lower mounting slots to the lower mountings on the upper mounting brackets.

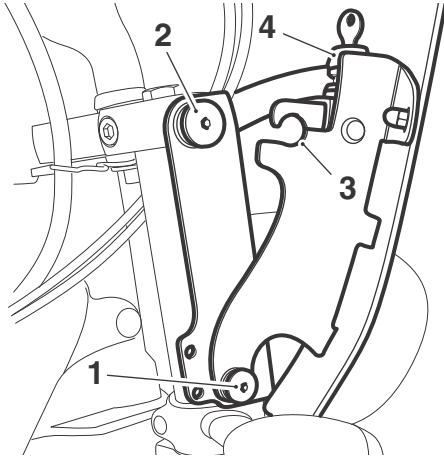

1. Lower mounting
2. Upper mounting
3. Windscreen upper mounting slot
4. Lock

Note:

- **An audible click can be heard when the windscreen upper mountings are fully engaged.**
2. Align the windscreen upper mounting slots to the mountings on the motorcycle. With a firm push, fully engage the upper mountings.

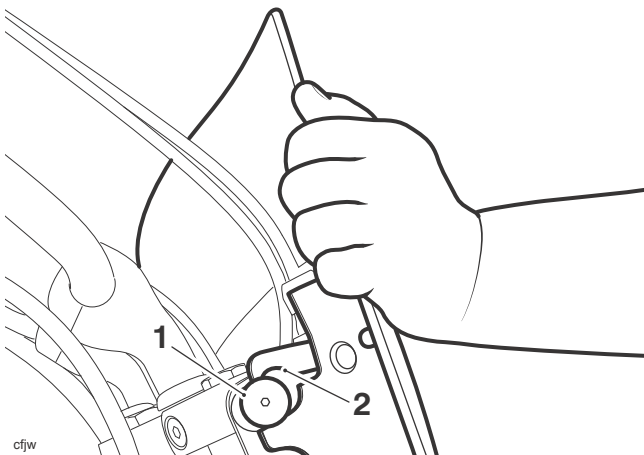

1. Upper mounting
2. Windscreen upper mounting slot
3. Turn the windscreen lock to the locked position.
4. Check the operation of the lock by unlocking and locking. Adjust the position of the lock if necessary.
5. Turn the windscreen lock to the unlocked position and remove the key.

Removing the Windscreen

To remove the windscreen, carry out the following procedure.

1. Turn the windscreen lock to the unlocked position.
2. Stand astride the front wheel and firmly grip both sides of the windscreen close to the upper mounting.

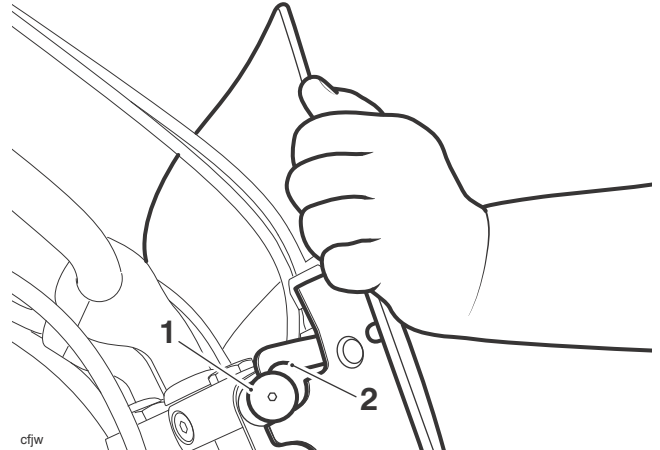

1. Upper mounting
2. Windscreen upper mounting slot

3. Pull the windscreen firmly to disengage the upper mountings. Then lift the windscreen up to disengage the lower mountings and completely remove from the motorcycle.

Warning

Never ride an accessory equipped motorcycle (including those fitted with Triumph approved windscreens and luggage systems) at speeds above 80 mph (130 km/h).

The presence of accessories such as windscreens and luggage systems will cause changes to the stability and handling of the motorcycle. Failure to allow for changes in motorcycle stability may lead to loss of control or an accident.

Remember that the 80 mph (130 km/h) limit will be reduced by the fitting of non-approved accessories, incorrect loading, worn tyres, overall motorcycle condition and poor road or weather conditions.

Warning

This motorcycle must not be operated above the legal road speed limit except in authorised closed-course conditions.



Warning

Never attempt to clean or adjust the windscreen while riding the motorcycle. Removal of the rider's hands from the handlebars while riding the motorcycle will diminish the ability of the rider to maintain the control of the motorcycle. Attempting to clean or adjust the windscreen while riding the motorcycle may result in loss of control of the motorcycle and an accident.



Warning

After fitting the windscreen mounting kit the motorcycle will exhibit new handling characteristics. Operate the motorcycle in a safe area free from traffic to gain familiarity with any new characteristics. Operation of the motorcycle when not familiar with any new handling characteristics may result in loss of motorcycle control and an accident.



Warning

If after the fitment of this accessory kit, you have any doubt about the performance of any aspect of the motorcycle, contact an authorised Triumph dealer and do not ride the motorcycle until the authorised dealer has declared it fit for use. Riding a motorcycle when there is any doubt as to any aspect of the performance of the motorcycle may result in loss of control of the motorcycle leading to an accident.



Warning

The windscreen is no substitute for a safety helmet or eye protection. Windscreens are designed to provide wind protection and increased rider comfort. They are not designed to provide protection in the event of a collision with another vehicle, the road, birds or any other objects. When riding a motorcycle, both rider and passenger must always wear a safety helmet, eye protection, gloves and trousers (close fitting around the knees and ankles). Although full protection is not possible, wearing correct protective clothing can reduce the risk of injury when riding.