

English

Fitting Instructions: Thunderbird A9528034

Thank you for choosing this Triumph genuine accessory kit. This accessory kit is the product of Triumph's use of proven engineering, exhaustive testing, and continuous striving for superior reliability, safety and performance.

Completely read all of these instructions before commencing the installation of the accessory kit in order to become thoroughly familiar with the kit's features and the installation process.

These instructions should be considered a permanent part of your accessory kit, and should remain with it even if your accessory equipped motorcycle is subsequently sold.

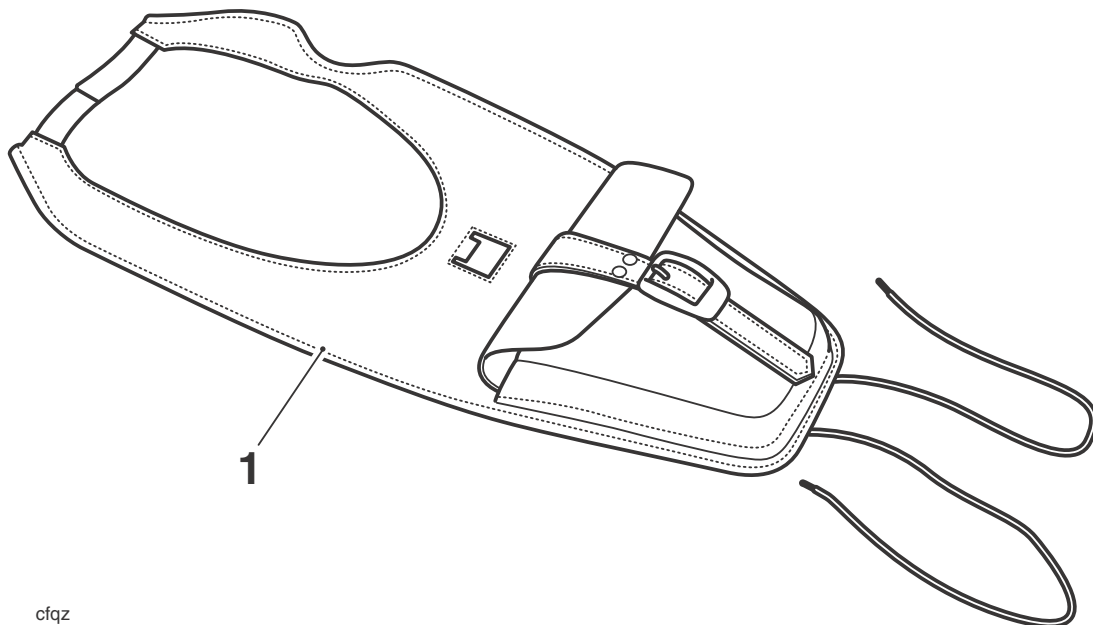

cfqz

Parts Supplied:

- | | |
|-----------------------|-------|
| 1. Leather tank panel | 1 off |
|-----------------------|-------|

Warning

This accessory kit is designed for use on Triumph Thunderbird motorcycles only and should not be fitted to any other manufacturer's motorcycle. Fitting this accessory kit to any other manufacturer's motorcycle will affect the performance, stability and handling of the motorcycle. This may affect the rider's ability to control the motorcycle and could cause an accident.

Warning

Always have Triumph approved parts, accessories and conversions fitted by a trained technician of an authorised Triumph dealer. The fitment of parts, accessories and conversions by a technician who is not of an authorised Triumph dealer may affect the handling, stability or other aspects of the motorcycle's operation which may result in loss of motorcycle control and an accident.

Warning

Throughout this operation, ensure that the motorcycle is stabilised and adequately supported to prevent risk of injury from the motorcycle falling.

Warning

A torque wrench of known accurate calibration must be used when fitting this accessory kit. Failure to tighten any of the fasteners to the correct torque specification may result in loss of motorcycle control and an accident.

1. Remove the rider's seat, as described in the service manual.
2. Disconnect the battery, negative (black) lead first.
3. Remove the instrument assembly as described in the service manual.
4. Remove the gasket from the instrument assembly. Retain the gasket if the motorcycle is to be returned to its original condition.

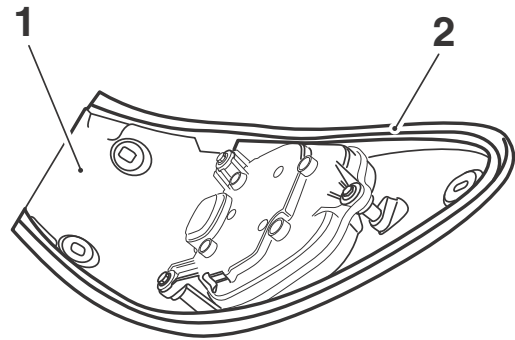

cfqx

- 1. Instrument assembly**
- 2. Gasket**

5. Position the leather tank panel in a central position on the fuel tank. Ensure that the locating tang, in the middle of the leather tank panel, is positioned under the rear mounting for the instrument assembly.

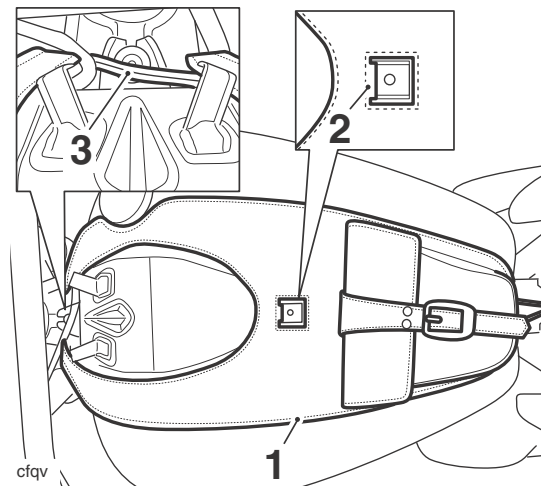

cfqv

- 1. Leather tank panel**
- 2. Locating tang**
- 3. Hook and loop tape**

- Place the instrument assembly onto the fuel tank. Ensure that the leather tank panel is positioned between the instrument assembly and the fuel tank.

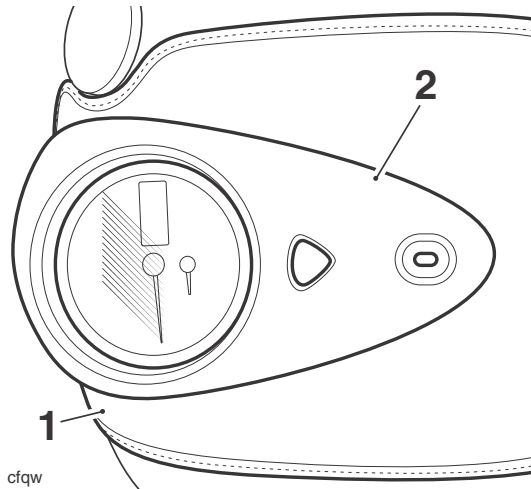

- Leather tank panel
- Instrument assembly

- Adjust the hook and loop straps if required.
- Secure the leather tank panel to the rear mounting of the fuel tank with the laces. Ensure that the laces are clear of the air intake.

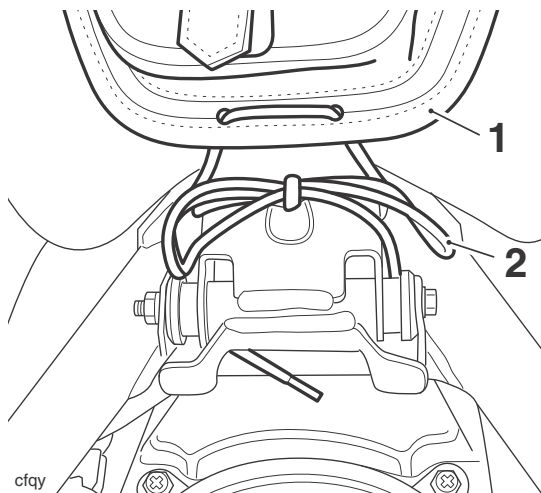

- Leather tank panel
- Laces

Note:

- Ensure when the leather tank panel is secured in position, it is clear of the fuel filler cap and is not positioned between the cap and the fuel tank.
- Refit the instrument assembly as described in the service manual.
 - Reconnect the battery, positive (identified with red tape) lead first.
 - Refit the rider's seat, as described in the service manual.

Warning

After fitting this accessory kit the motorcycle will exhibit new handling characteristics. Operate the motorcycle in a safe area free from traffic to gain familiarity with any new characteristics. Operation of the motorcycle when not familiar with the new handling characteristics may result in loss of motorcycle control and an accident.

Warning

If, after fitment of this accessory kit, you have any doubt about the performance of any aspect of the motorcycle, contact an authorised Triumph dealer and do not ride the motorcycle until the authorised dealer has declared it fit for use. Riding a motorcycle when there is any doubt as to any aspect of the performance of the motorcycle may result in loss of control of the motorcycle leading to an accident.

Warning

Never ride an accessory equipped motorcycle at speeds above 80 mph (130 km/h). The presence of accessories will cause changes in the stability and handling of the motorcycle. Failure to allow for changes in motorcycle stability may lead to loss of control or an accident. Remember that the 80 mph (130 km/h) limit will be reduced by the fitting of non-approved accessories, incorrect loading, worn tyres, overall motorcycle condition and poor road or weather conditions.

Warning

The motorcycle must not be operated above the legal road speed limit except in closed-course conditions.

Warning

Only operate this Triumph motorcycle at high speed in closed-course on road competition or on closed-course racetracks. High speed operation should only be attempted by riders who have been instructed in the techniques necessary for high speed riding and are familiar with the motorcycle's characteristics in all conditions. High speed operation in any other circumstances is dangerous and will lead to loss of motorcycle control and an accident.