

Fitting Instructions:
Bonneville and Bonneville T100
A9528020, A9528021 and A9528022

Thank you for choosing this Triumph genuine accessory kit. This accessory kit is the product of Triumph's use of proven engineering, exhaustive testing, and continuous striving for superior reliability, safety and performance.

Completely read all of these instructions before commencing the installation of the accessory kit in order to become thoroughly familiar with the kit's features and the installation process.

These instructions should be considered a permanent part of your accessory kit, and should remain with it even if your accessory equipped motorcycle is subsequently sold.

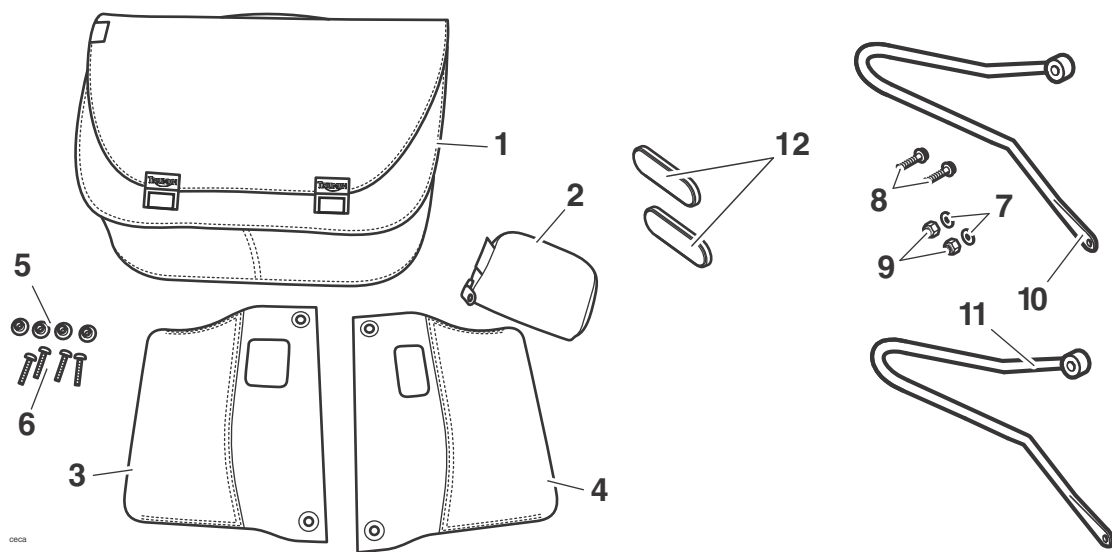

Parts Supplied:

	LH Kit	RH Kit	Pair Kit
1. City Bag	1 off	1 off	2 off
2. Rain Cover and Pouch	1 off	1 off	2 off
3. Harness Pad, LH	1 off	-	1 off
4. Harness Pad, RH	-	1 off	1 off
5. Flanged Sleeve	2 off	2 off	4 off
6. Screw, M6 x 30 mm	2 off	2 off	4 off
7. Washer, M8	1 off	1 off	2 off
8. Screw, threadlock, M8 x 20 mm	1 off	1 off	2 off
9. Lock nut, M8	1 off	1 off	2 off
10. Pannier rail, LH	1 off	-	1 off
11. Pannier rail, RH	-	1 off	1 off
12. Reflector, red	1 off	1 off	2 off
13. Cleaning wipe (not shown)	1 off	1 off	1 off



Warning

This accessory kit is designed for use on Triumph Bonneville and Bonneville T100 motorcycles only and should not be fitted to any other manufacturer's motorcycle. Fitting this accessory kit to any other manufacturer's motorcycle may interfere with the rider and could affect the stability and handling of the motorcycle leading to loss of motorcycle control and an accident.



Warning

Always have Triumph approved parts, accessories and conversions fitted by a trained technician of an authorised Triumph dealer. The fitment of parts, accessories and conversions by a technician who is not of an authorised Triumph dealer may affect the handling, stability or other aspects of the motorcycles operation which may result in loss of motorcycle control and an accident.



Warning

A torque wrench of known accurate calibration must be used when fitting this accessory kit. Failure to tighten any of the fasteners to the correct torque specification may result in loss of motorcycle control and an accident.



Warning

Throughout this operation, ensure that the motorcycle is stabilised and adequately supported on a paddock stand to prevent risk of injury from the motorcycle falling.

1. Undo and remove the screws (and flanged sleeves if fitted) located at the rear of the seat.

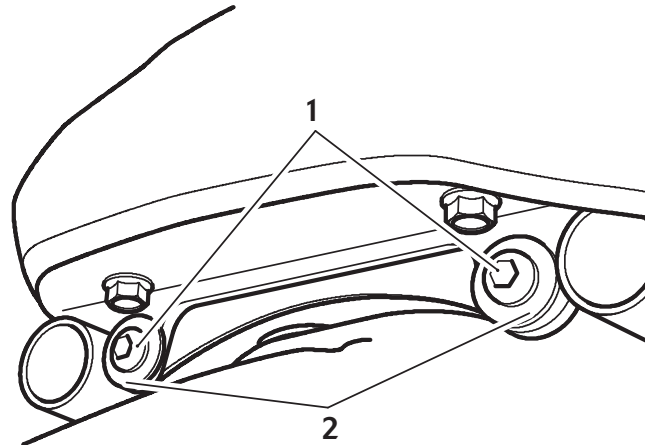

1. Screws
2. Flanged sleeves (if fitted)

2. Remove the seat.
3. Disconnect the battery, negative (black) lead first.

To fit the right hand pannier rail and harness pad

4. Slacken and remove the right hand rear suspension unit upper mounting bolt and washer. Discard the bolt.

Note:

- **The bolt used to secure the upper suspension unit to its mounting point must not be re-used. Retain the washer for later use.**

5. Slacken and remove the nut securing the right hand passenger footrest to the frame.

Note:

- **Retain the nut for use if the motorcycle is returned to original condition.**

6. Fit the right hand pannier rail, engaging it with the suspension unit upper mounting point and passenger footrest bolt.

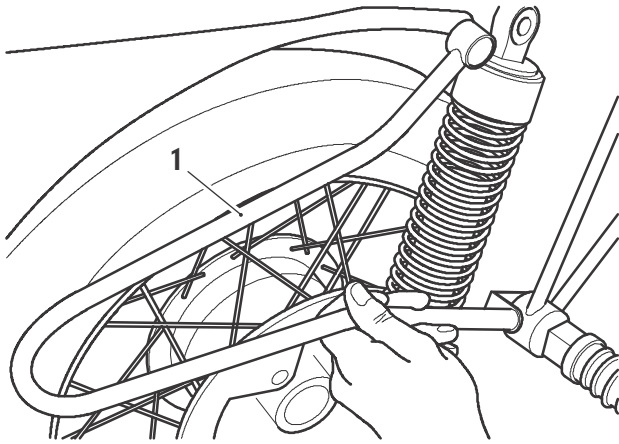

1. Pannier rail

7. Secure the rear suspension unit and pannier rail to the upper mounting point using the original washer and M8 x 20 mm threadlock screw supplied. Tighten the screw to **27 Nm**.
8. Fit an M8 lock nut and washer from the kit to the right hand passenger footrest and tighten to **27 Nm**.

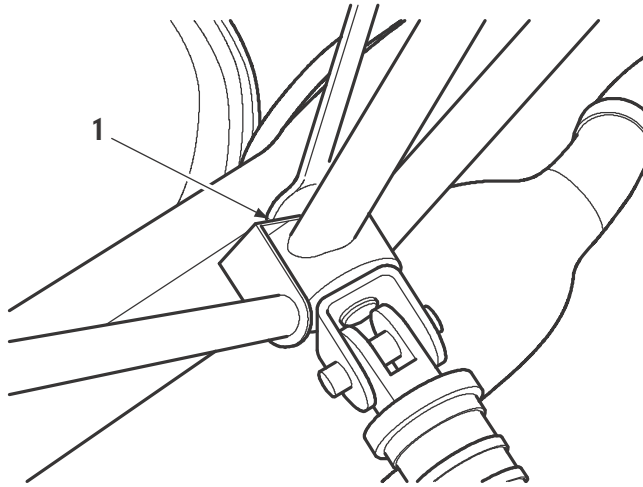

1. M8 lock nut and washer location

9. Release the alarm multiplug from its mounting position on the frame then disconnect the rear light unit plug.

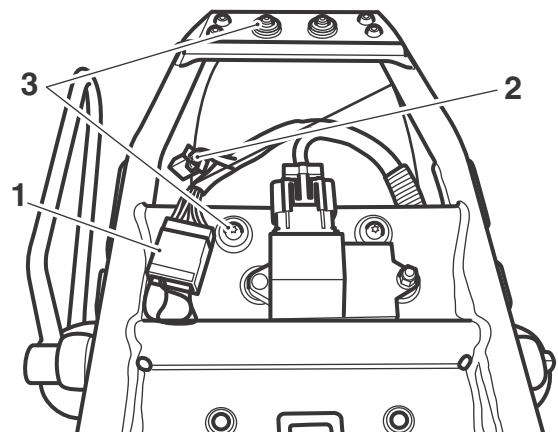

Carburettor model shown

1. Alarm multiplug
2. Rear light unit plug
3. Right hand mudguard fixings

10. Undo and remove both right hand mudguard fixings.

Note:

- **Retain the fixings for use if the motorcycle is returned to original condition.**
11. Recover the right hand harness pad and two flanged sleeves from the kit and thread the rear light unit plug through the access hole in the pad.

12. Insert a flanged sleeve into each of the pad's fixing holes then align the pad to the mudguard fixing holes as shown.

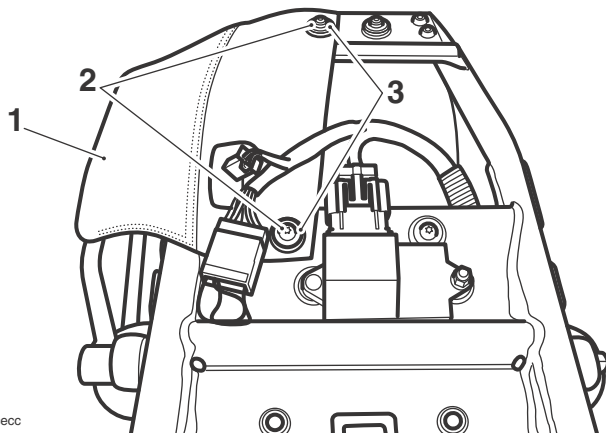

Carburettor model shown

1. Right hand harness pad
2. Right hand mudguard fixings
3. Flanged sleeves

13. Secure the harness pad and the mudguard with two of the supplied M6 x 30 mm fixings. Tighten both fixings to **10 Nm**.
14. If only the right hand pannier is to be fitted, proceed to step 25.

To fit the left hand pannier rail and harness pad

15. Slacken and remove the left hand rear suspension unit upper mounting bolt and washer. Discard the bolt.

Note:

- **The bolt used to secure the upper suspension unit to its mounting point must not be re-used. Retain the washer for later use.**

16. Slacken and remove the nut securing the left hand passenger footrest to the frame.

Note:

- **Retain the nut for use if the motorcycle is returned to original condition.**

17. Fit the left hand pannier rail, engaging it with the suspension unit upper mounting point and passenger footrest bolt.

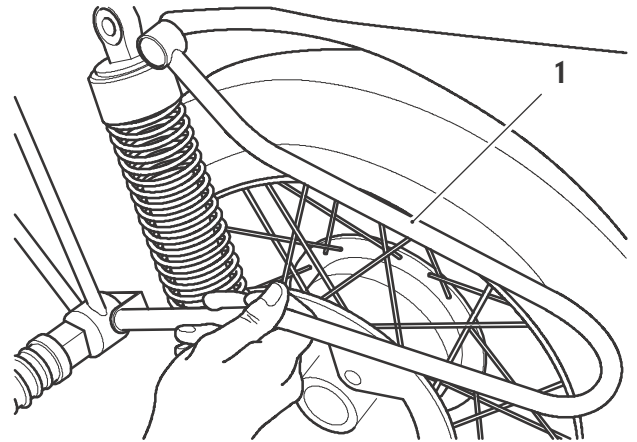

1. Pannier rail

18. Secure the rear suspension unit and pannier rail to the upper mounting point using the original washer and M8 x 20 mm threadlock screw supplied. Tighten the screw to **27 Nm**.
19. Fit an M8 lock nut and washer from the kit to the left hand passenger footrest and tighten to **27 Nm**.

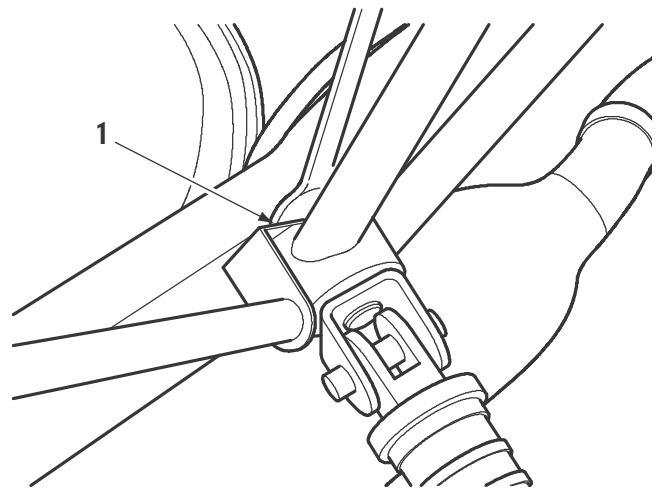

1. M8 lock nut and washer location

20. **EFI Models:** Release the relay unit from its position on the frame.

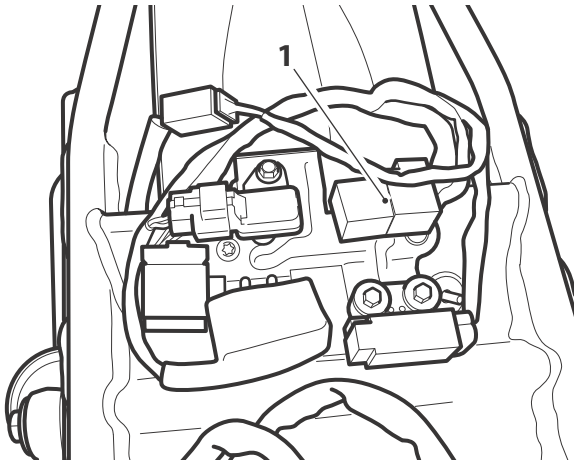

EFI Model shown

1. Relay unit

21. Undo and remove both left hand mudguard fixings.

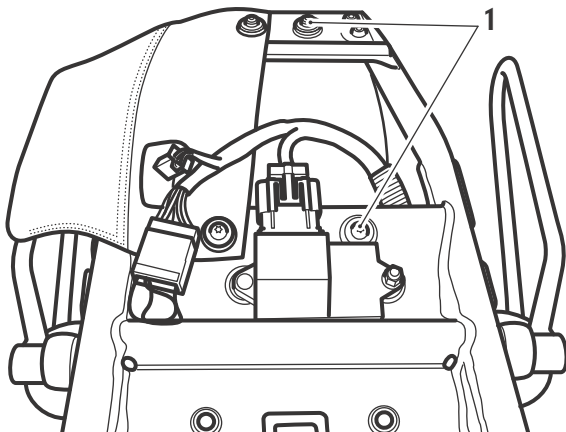

Carburettor model shown

1. Left hand mudguard fixings

Note:

- **Retain the fixings for use if the motorcycle is returned to original condition.**

22. Recover the left hand harness pad and the remaining flanged sleeves from the kit.

23. Insert a flanged sleeve into each of the pad's fixing holes then align the pad to the mudguard fixing holes as shown.

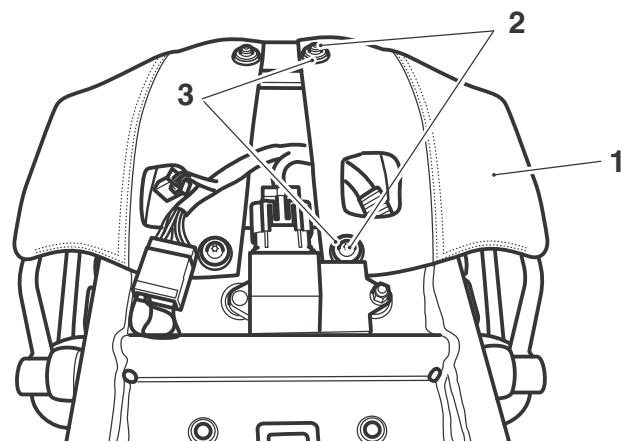

Carburettor model shown

- 1. Left hand harness pad**
2. Left hand mudguard fixings
3. Flanged sleeves

24. Secure the harness pad and mudguard with the remaining M6 x 30 mm fixings. Tighten both fixings to **10 Nm**.

25. Reconnect the rear light unit plug, then re-attach the alarm multiplug to the frame.

EFI Models: Re-attach the relay unit to its mounting point on the frame.

26. Reconnect the battery, positive (red) lead first.

27. Fit the seat as described in the Owner's Handbook.

28. Check the operation of the rear light unit. Rectify if necessary.

Reflector Fitment - United States, Canada and Singapore Only

Note:

- If side reflectors are not required in your country or region, continue from step 33.

Notice

Failure to fit a reflector to each city bag as shown contravenes federal law and renders the motorcycle illegal for road use in the United States, Canada and Singapore. Always fit the reflectors as shown.



Caution

When fitting self-adhesive parts care must be taken to ensure positioning is correct and accurate. Once the adhesive has been attached to the mounting surface, there is no satisfactory method of removal and re-positioning if incorrectly aligned. Initial bonding is instant, full bonding is achieved after 72 hours.

Note:

- Read the warning notices printed on the cleaning wipe packet in the fitting kit.
 - The surfaces to which the reflectors are affixed must be clean and dry to ensure that the adhesive has a sound base to adhere to. Use the cleaning wipe supplied for this purpose.
29. Clean the mounting surface area of the city bag with the cleaning wipe provided.

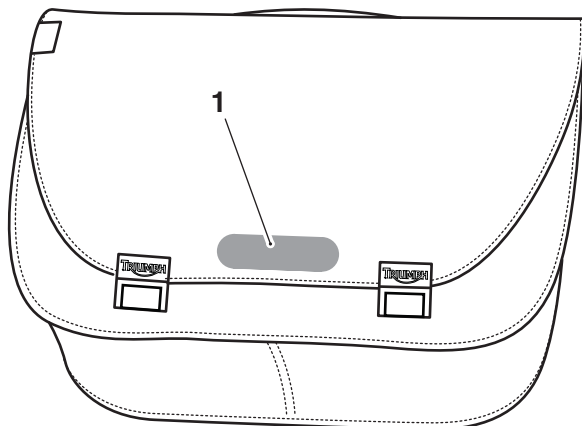

1. Cleaning area

30. Remove the protective film from the adhesive pad on the rear of the reflector.

31. Carefully locate the reflector on to the city bag centrally between the straps as shown below. Apply firm pressure to the entire reflector to ensure a good bond is achieved.

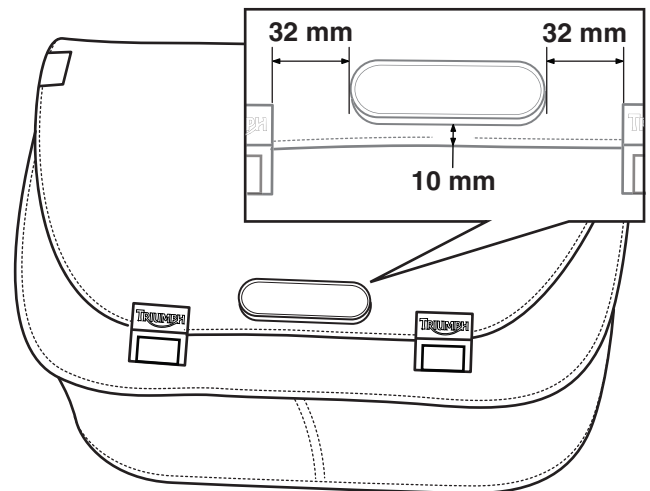

Location for Reflector

32. Repeat steps 29 to 31 for the other city bag if purchased as a pair.

To fit the city bag

33. To fit either city bag, position the city bag so that the pannier rail slides into the pocket on the inward facing side of the bag.

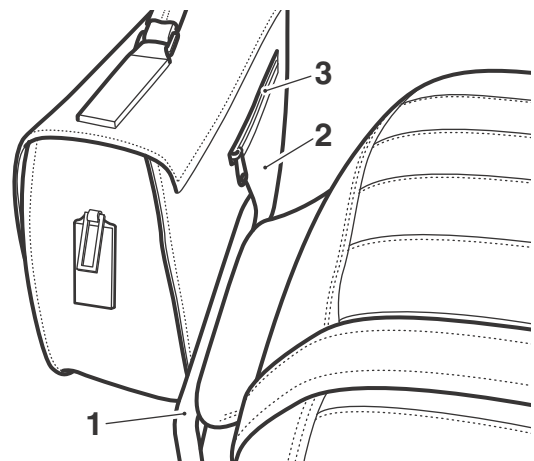

1. Pannier rail (right hand shown)

2. Pocket

3. Security clasp location

34. Undo the zipper above the pocket of the city bag to reveal the two security clasps.

35. Secure the city bag to the motorcycle by connecting both security clasps to the corresponding clasps beneath the harness pad.

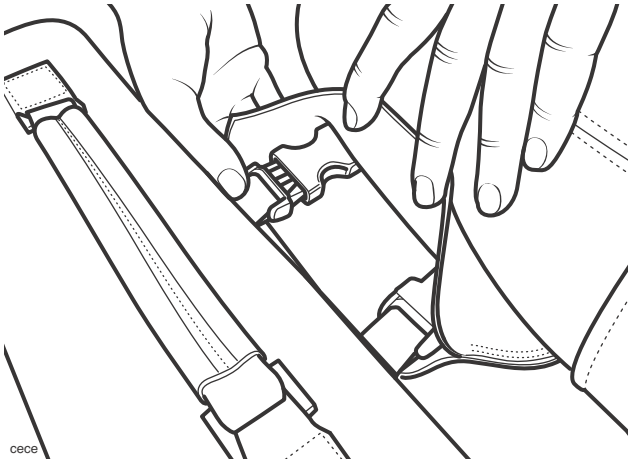

36. If required, the supplied rain cover can be fitted around the city bag as shown.

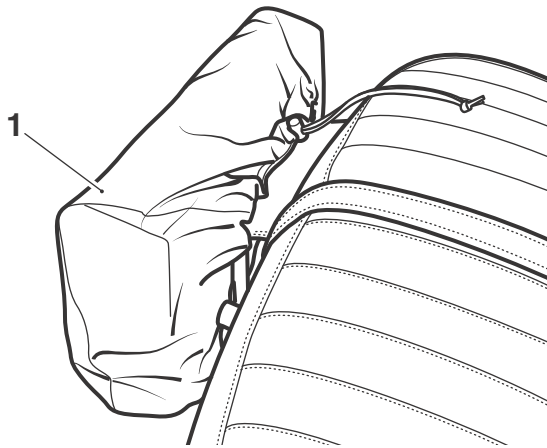

1. Rain cover

! Warning

If, after fitment of the accessory kit, there is any doubt as to any aspect of the performance of the motorcycle, contact an authorised Triumph dealer and do not ride the motorcycle until the authorised dealer has declared it fit for use. Riding a motorcycle when there is any doubt as to any aspect of the performance of the motorcycle may result in loss of control of the motorcycle leading to an accident.

! Warning

The maximum safe load for each pannier is 3 kg (6.6 lbs). Never exceed this loading limit as this may cause the motorcycle to become unstable leading to loss of control and an accident.

! Warning

After fitting this accessory kit, operate the motorcycle in a safe area free from traffic to gain familiarity with the new handling characteristics. Operation when not familiar with the new characteristics of the motorcycle may result in loss of control and an accident.

! Warning

Never ride an accessory equipped motorcycle at speeds above the legal speed limit or at a speed inappropriate for the circumstances. Speeds in excess of 130 km/h (80 mph) should not be attempted on an accessory equipped motorcycle even where the legal speed limit permits this. The presence of accessories will cause changes in the stability and handling of the motorcycle. Failure to allow for changes in motorcycle stability may lead to loss of control or an accident. Remember that the 130 km/h (80 mph) absolute limit will be reduced by the fitting of non-approved accessories, incorrect loading, worn tyres, overall motorcycle condition and poor road or weather conditions.

! Warning

This motorcycle must not be operated above the legal road speed limit except in authorised closed-course conditions.

! Warning

Only operate this Triumph motorcycle at high speed in closed course, on-road competition or on closed course racetracks. High-speed operation should only be attempted by riders who have been instructed in the techniques necessary for high-speed riding and are familiar with the motorcycle's characteristics in all conditions. High-speed operation in any other circumstances is dangerous and will lead to loss of motorcycle control and an accident.