

### Fitting Instructions: Tiger Sport and Tiger 1050 A9510102

Thank you for choosing this Triumph genuine accessory kit. This accessory kit is the product of Triumph's use of proven engineering, exhaustive testing, and continuous striving for superior reliability, safety and performance.

Completely read all of these instructions before commencing the installation of the accessory kit in order to become thoroughly familiar with the kit's features and the installation process.

These instructions should be considered a permanent part of your accessory kit, and should remain with it even if your accessory-equipped motorcycle is subsequently sold.

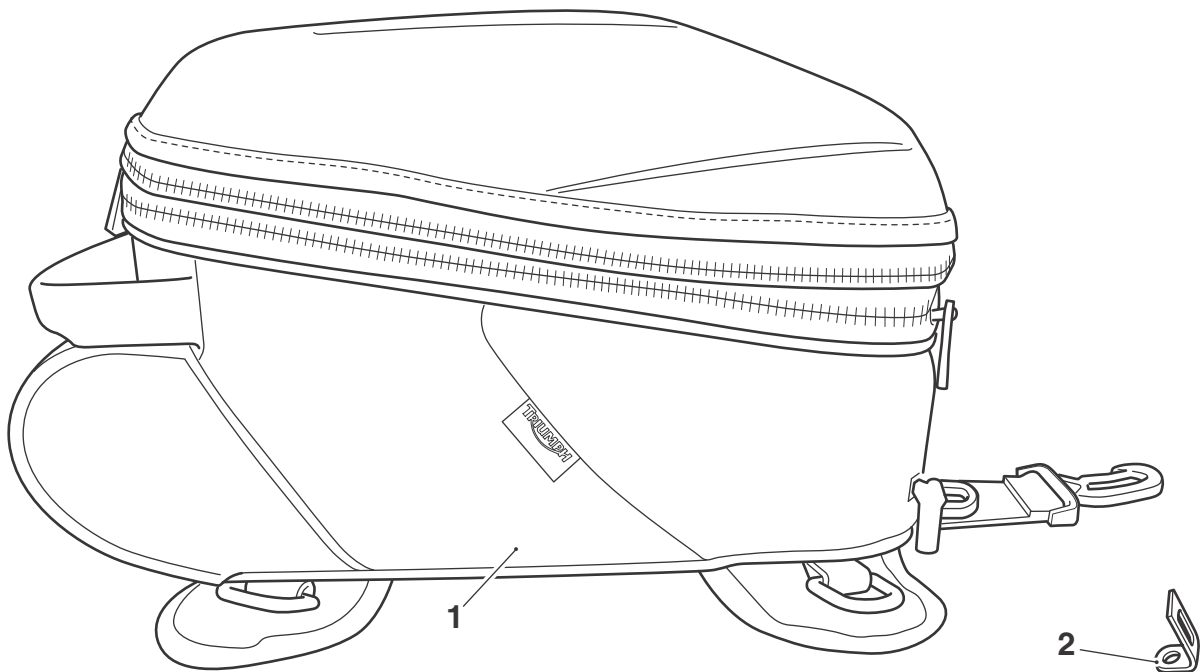

#### Parts Supplied:

1. Tank bag, 15 - 20 litre	1 off	2. Front bracket	1 off
----------------------------	-------	------------------	-------



## Warning

This accessory kit is designed for use on Triumph Tiger Sport and Tiger 1050 motorcycles only and should not be fitted to any other Triumph model, or to any other manufacturer's motorcycle. Fitting this accessory kit to any other Triumph model, or to any other manufacturer's motorcycle will affect the performance, stability and handling of the motorcycle. This may affect the rider's ability to control the motorcycle and could cause an accident.



## Warning

Always have Triumph approved parts, accessories and conversions fitted by a trained technician of an authorised Triumph dealer. The fitment of parts, accessories and conversions by a technician who is not of an authorised Triumph dealer may affect the handling, stability or other aspects of the motorcycle's operation, which may result in loss of motorcycle control and an accident.



## Warning

Throughout this operation, ensure that the motorcycle is stabilised and adequately supported to prevent risk of injury from the motorcycle falling.



## Warning

A torque wrench of known accurate calibration must be used when fitting this accessory kit. Failure to tighten any of the fasteners to the correct torque specification may result in loss of motorcycle control and an accident.



## Warning

Remove the shoulder strap from the tank bag before mounting to the motorcycle.  
Operation of the motorcycle with the shoulder strap fitted may result in loss of motorcycle control and an accident.

### Note:

- **When using the tank bag, always pack heavier items at the bottom of the bag.**
- **Ensure the underside of the tank bag is clean and dry prior to fitting.**

## Installing the Tank Bag Front Bracket

1. Remove the fixing securing the fuel tank front cover, located to the rear of the top yoke.
2. Install the tank bag front bracket as shown, using the original fixing from the fuel tank front cover. Tighten the fixing to **9 Nm**.

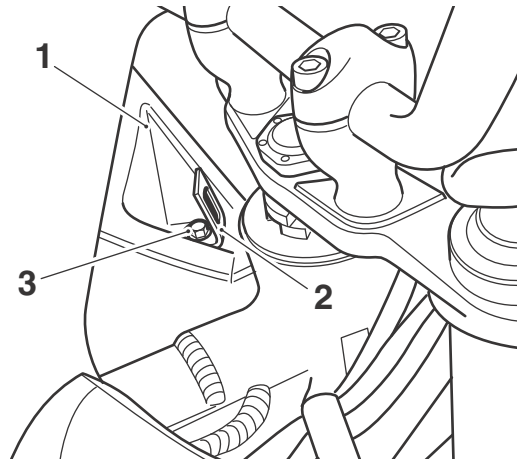

ceec

1. Fuel tank front cover
2. Tank bag front bracket
3. Fixing

## Installing the Tank Bag

1. Make sure the tank bag magnets are folded under the tank bag to prevent them from attaching to the fuel tank.
2. Position the tank bag to the fuel tank and attach the tank bag front clip to the front bracket as shown below.

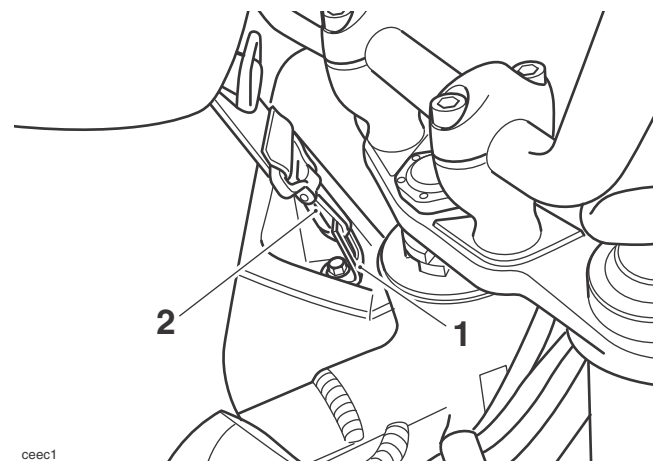

ceec1

1. Tank bag front bracket
2. Tank bag front clip

- Working from the front of the tank bag to the rear, lower the tank bag on to the tank, at the same time folding out the magnetic fixings following the form of the fuel tank.

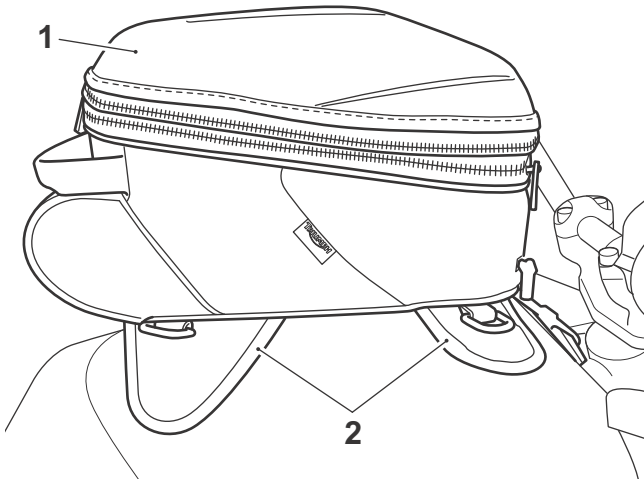

- Tank bag
- Magnetic fixings

### Cleaning

#### **! Caution**

Use of chemicals or high-pressure spray washers is not recommended for cleaning the tank bag. Using chemicals or pressure washers may damage the tank bag.

To help maintain its appearance, clean the tank bag using a sponge or cleaning cloth with low alkaline soap and water.

#### **! Warning**

Ensure the tank bag does not restrict the movement of the steering or cause any cables or wiring harnesses to bind.

Move the handlebars to left and right full lock while checking that cables and wiring harnesses do not bind. A cable or harness which binds will restrict the steering. Any restriction of the steering may cause loss of control and an accident.

#### **! Warning**

The maximum safe load for the tank bag is 3 kg (6.6 lbs). Never exceed this loading limit as this may cause the motorcycle to become unstable leading to loss of control and an accident.

#### **! Warning**

After fitting the accessory kit the motorcycle will exhibit new handling characteristics. Operate the motorcycle in a safe area free from traffic to gain familiarity with any new characteristics. Operation of the motorcycle when not familiar with any new handling characteristics may result in loss of motorcycle control and an accident.

#### **! Warning**

Never ride an accessory-equipped motorcycle at speeds above 80 mph (130 km/h). The presence of accessories will cause changes in the stability and handling of the motorcycle. Failure to allow for changes in motorcycle stability may lead to loss of control or an accident. Remember that the 80 mph (130 km/h) limit will be reduced by the fitting of non-approved accessories, incorrect loading, worn tyres, overall motorcycle condition and poor road or weather conditions.

#### **! Warning**

The motorcycle must not be operated above the legal road speed limit except in closed course conditions.

#### **! Warning**

Only operate this Triumph motorcycle at high speed in closed course, on-road competitions or on closed course race tracks. High speed operation should only be attempted by riders who have been instructed in the techniques necessary for high speed riding and are familiar with the motorcycle's characteristics in all conditions. High speed operation in any other circumstances is dangerous and will lead to loss of motorcycle control and an accident.

#### **! Warning**

The strong magnets used to retain the tank bag to the fuel tank may adversely affect a variety of electronic devices and electronic storage units such as (but not limited to): electronic medical devices, mobile phones, personal data assistants (PDAs), lap top computers, floppy discs and other computer storage media, personal music players, digital cameras, memory cards, music/video cassettes, etc.

Ensure that if carrying any of these items, they are stored as far away from the magnets as possible. It is recommended that any such items are carried elsewhere on the motorcycle or in the pocket under the lid.

Carriage of any such items is entirely at your own risk.