



## Accessory Fitting Instructions

| Top Box Kit - Silver |   |
|----------------------|---|
| Kit Number           | Models Affected   |
| A9500876             | Tiger 900, Tiger 900 GT, Tiger 900 GT Pro, Tiger 900 GT (LRH), Tiger 900 GT Aragon Edition, Tiger 900 Rally, Tiger 900 Rally Pro, Tiger 900 Rally Aragon Edition, Tiger 850 Sport |
| A9500830             | Tiger 1200 GT, Tiger 1200 GT Pro, Tiger 1200 Rally Pro, Tiger 1200 GT Explorer, Tiger 1200 Rally Explorer   |
| Top Box Kit - Black  |   |
| Kit Number           | Models Affected   |
| A9500877<br>A9500977 | Tiger 900, Tiger 900 GT, Tiger 900 GT Pro, Tiger 900 GT (LRH), Tiger 900 GT Aragon Edition, Tiger 900 Rally, Tiger 900 Rally Pro, Tiger 900 Rally Aragon Edition, Tiger 850 Sport |
| A9500835<br>A9500935 | Tiger 1200 GT, Tiger 1200 GT Pro, Tiger 1200 Rally Pro, Tiger 1200 GT Explorer, Tiger 1200 Rally Explorer   |

Thank you for choosing this Triumph genuine accessory kit. This accessory kit is the product of Triumph's use of proven engineering, exhaustive testing, and continuous striving for superior reliability, safety and performance.

Completely read all of these instructions before commencing the installation of the accessory kit in order to become thoroughly familiar with the kit's features and the installation process.

These instructions should be considered a permanent part of your accessory kit, and should remain with it even if your accessory equipped motorcycle is subsequently sold.

### Parts Supplied:

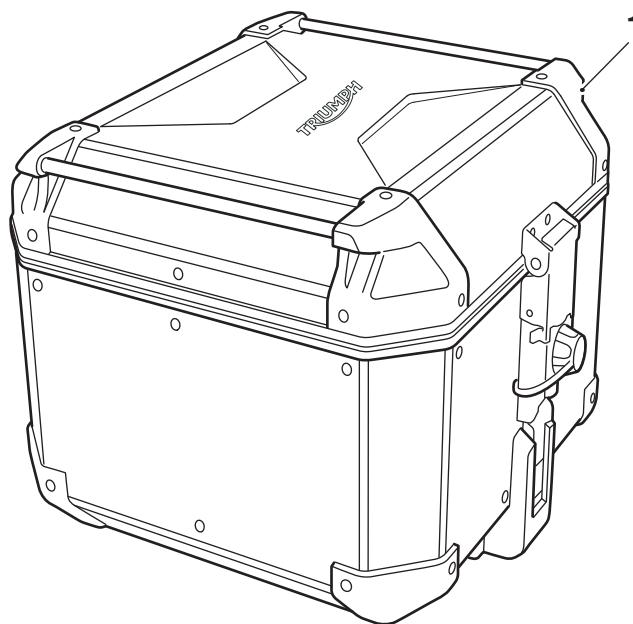

|            |       |
|------------|-------|
| 1. Top box | 1 off |
|------------|-------|

## Warning

Fit only genuine Triumph accessories to those models approved by Triumph as listed in the associated Triumph fitting instructions. The accessory kits covered in this instruction are designed for use on specific models of Triumph motorcycle. The accessory kits and the models applicable are listed at the start of the instruction. They should never be fitted to any other Triumph model or to any other manufacturer's motorcycle. Fitting an accessory kit to a Triumph model not listed, or to any other manufacturer's motorcycle will affect the performance, stability and handling of the motorcycle. This may affect the rider's ability to control the motorcycle and could result in an accident causing severe injuries or death.

## Warning

Always have Triumph approved parts, accessories and conversions fitted by a trained technician of an authorised Triumph dealer. The fitment of parts, accessories and conversions by a technician who is not of an authorised Triumph dealer may affect the handling, stability or other aspects of the motorcycle's operation which may result in loss of motorcycle control and an accident.

## Warning

Make sure the motorcycle is supported. A correctly supported motorcycle will help prevent it from falling. An unstable motorcycle may fall, causing injury to the operator or damage to the motorcycle.

### Note:

- Triumph offers a broad range of approved genuine accessories for your motorcycle. We cannot therefore cover all possible equipment variations in these instructions. For removal and installation of Triumph Genuine Accessories, always refer to the instructions supplied with the respective accessory kit. To obtain additional copies of any Triumph accessory instructions, visit [www.triumphinstructions.com](http://www.triumphinstructions.com) or contact your authorised Triumph dealer.

## Lock Barrel Fitment

- Take a lock barrel (supplied with the motorcycle). Align the tumblers to the slot and push the barrel into position until it clicks into place.

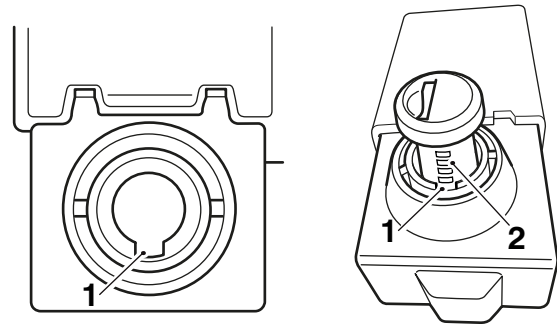

- Slot
- Tumblers

### Note:

- The lock barrel will only fit one way.
- Check the operation of the lock barrel.

## Fitting the Top Box

- Position the top box such that the mounting slots on the bottom of the top box locate with the mounting hooks on the sliding carriage.

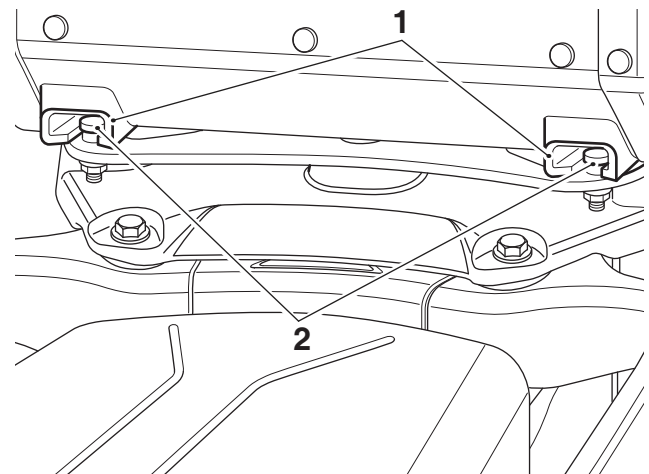

- Mounting slots
- Mounting hooks

- Push the top box forwards against the mounting hooks and lower the top box until the locking mechanism engages with the rear latch.

**Note:**

- **The top box will lock to the sliding carriage when the latch on the sliding carriage aligns to the locking mechanism of the top box.**
3. Lock the top box to the sliding carriage by pushing downwards to fully engage it. An audible click can be heard when the locking mechanism on the bottom surface of the top box is correctly latched to the sliding carriage. If an audible click cannot be heard the top box may not be correctly latched to the sliding carriage.

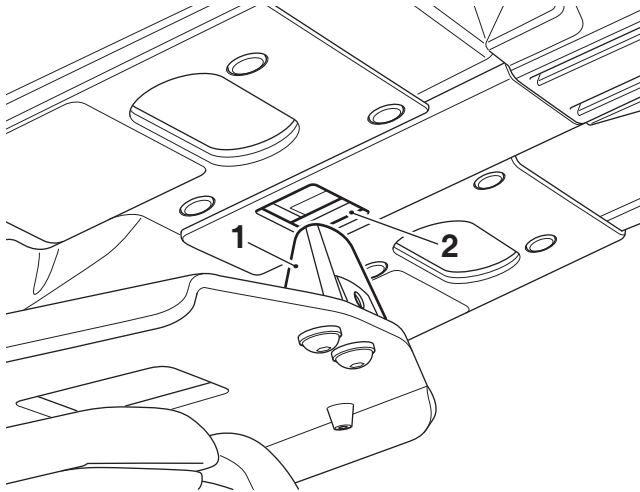

1. Latch
2. Locking mechanism



**Warning**

To prevent detachment of the top box while riding, after fitting always grasp the top box and pull firmly upwards and to the rear. If the top box is not correctly secured, it will detach from the sliding carriage. A loose or detached top box could cause loss of motorcycle control and an accident.

**Note:**

- **It is recommended to have the top box in the locked condition while riding the motorcycle.**

4. Check that the top box is securely locked to the sliding carriage.

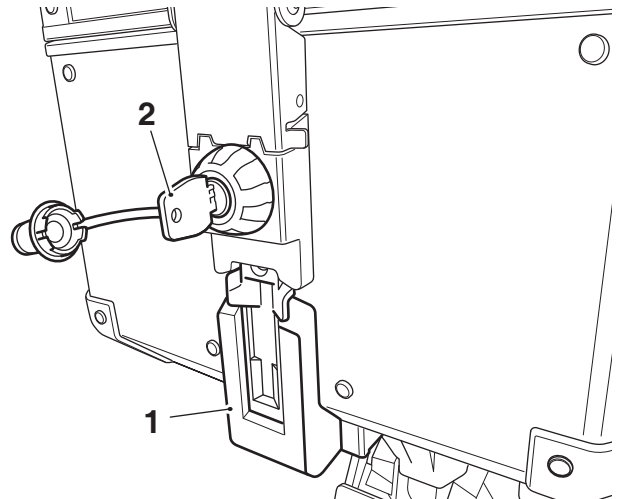

1. Release lever (locked position)
2. Key slot (shown in LOCK position)

**Removing the Top Box**

5. Insert the key into the lock. Turn the key to the UNLOCK position and lift the release lever.
6. Lift the rear of the top box to release the locking mechanism from the rear latch. Slide the top box rearward to disengage the front mounting hooks and lift the top box away from the sliding carriage.

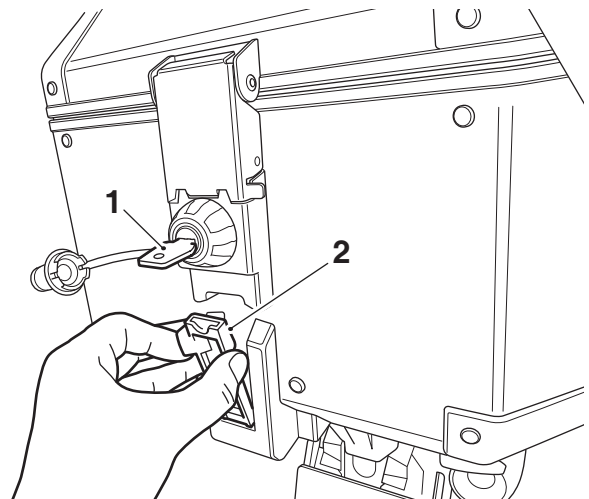

1. Key slot (shown in UNLOCK position)
2. Release lever (open position)

## Top Box Operation

1. To unlock and open the top box lid, insert the key and turn it to the UNLOCK position, then release the top box lid latch. The lid can then be opened.

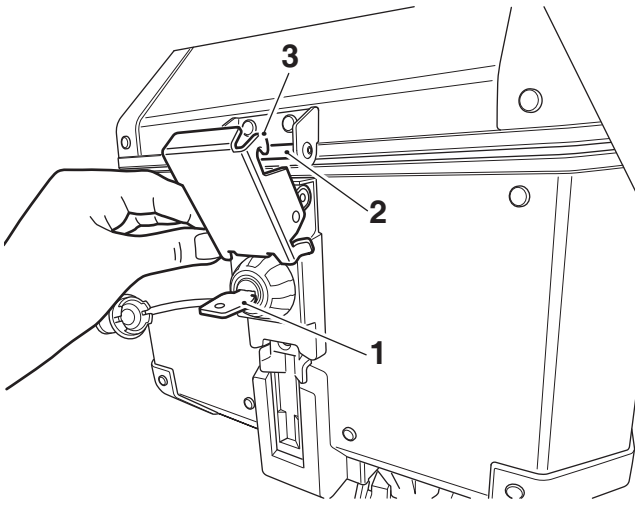

1. Key slot (shown in UNLOCK position)
2. Locking bar
3. Lid latch handle (open position)

2. To lock the lid of the top box, fully close the lid, lock the lid latch handle in position and turn the key to the LOCK position. Remove the key.

## Top Box - Lock Barrel Replacement

### Latch Housing Removal

1. Open the top box lid and locate the six screws retaining the latch housing to the top box. Remove the six screws and washers and remove the latch housing from the top box. Retain the screws and washers for reuse.

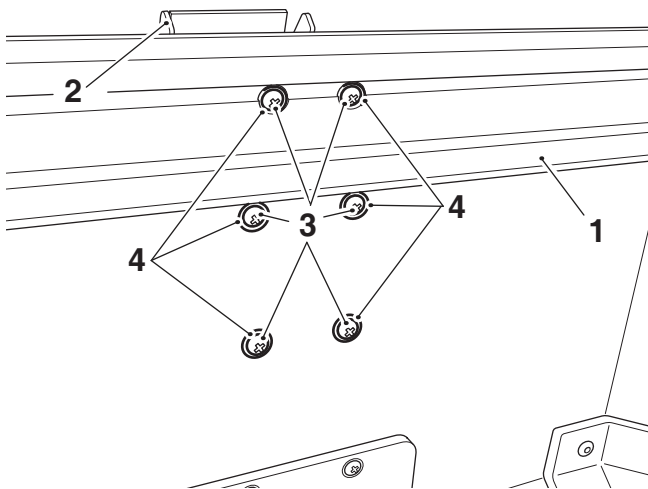

1. Top box
2. Latch housing
3. Fixings
4. Washers

2. Remove the locking cursor from the latch housing. Retain the locking cursor for reuse.

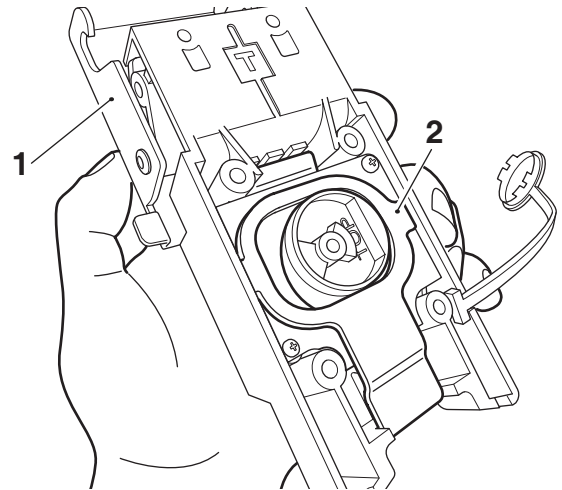

1. Latch housing
2. Locking cursor

3. Remove the retaining plate from the latch housing. Retain the fixings and retaining plate for reuse.

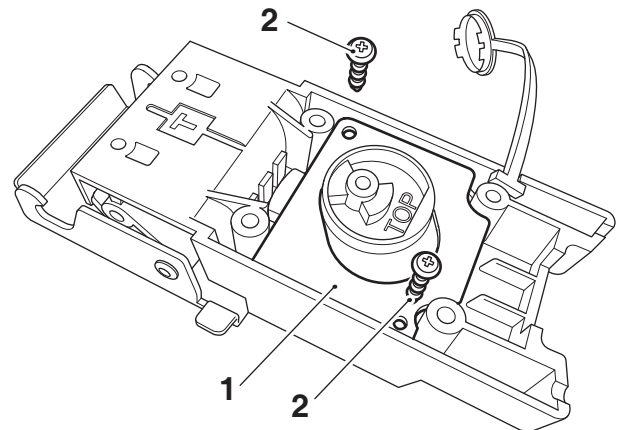

1. Retaining plate
2. Fixings

4. Make sure the cam is in the unlocked position with the locking section of the cam in the orientation shown.

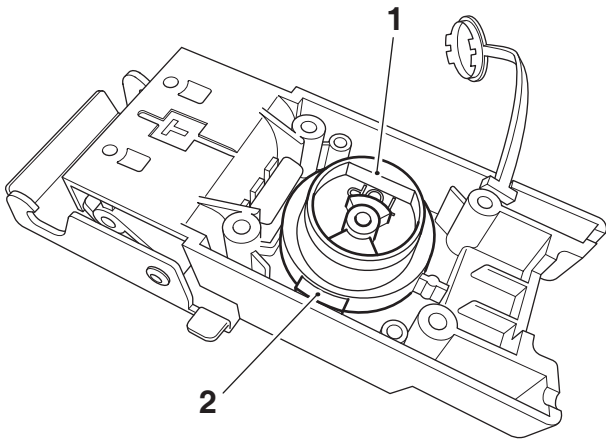

1. Cam
2. Locking section

5. Lift and remove the cam from the latch housing making sure the ball bearing and spring do not become separated from the latch housing. Retain the cam for reuse.

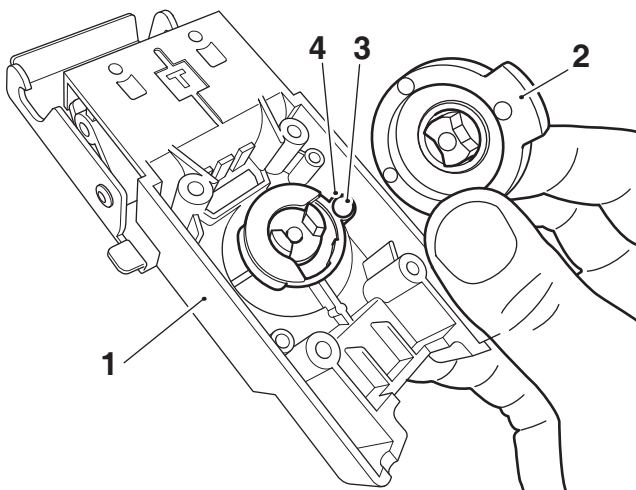

1. Latch housing
2. Cam
3. Ball bearing
4. Spring

**Note:**

- Make sure the key is inserted into the lock barrel prior to removing the lock barrel from the lock assembly.

6. Press the retaining lock pin into the lock barrel and remove the lock barrel from the front of the latch housing.

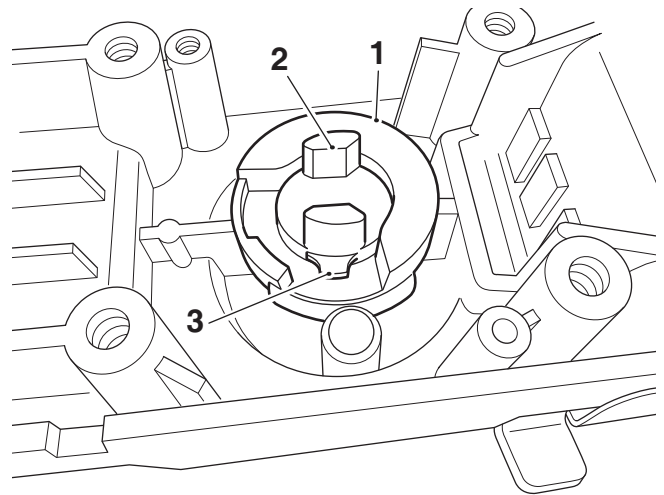

1. Latch housing
2. Lock barrel
3. Retaining lock pin

**Latch Housing Fitment**

7. Making sure the ball bearing remains correctly located in the latch housing, refit the cam in the locked position with the locking section of the cam in the orientation shown.

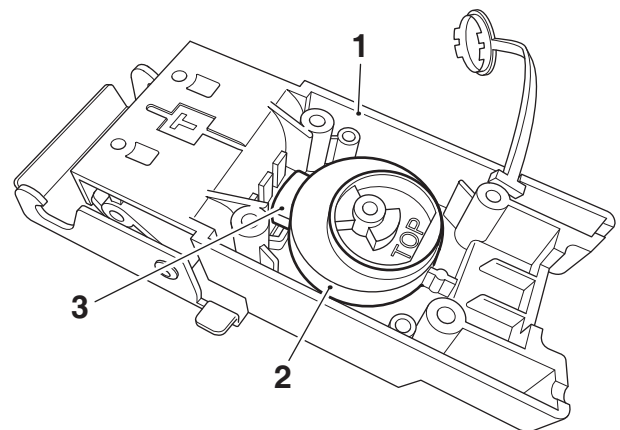

1. Latch housing
2. Cam
3. Locking section

- Refit the retaining plate on to the latch housing and secure with the original fixings. Tighten the fixings to 1 Nm.

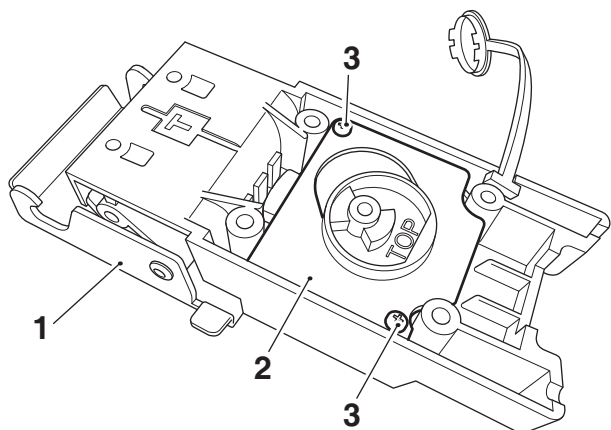

- Latch housing
- Retaining plate
- Fixings

- Refit the locking cursor over the cam onto the latch housing, left hand shown.

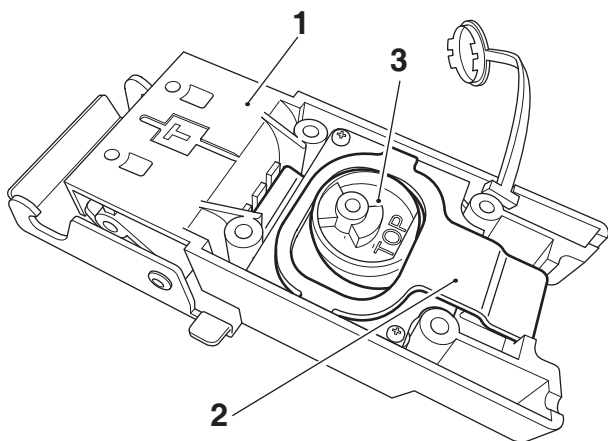

- Latch housing
- Locking cursor
- Cam

- Refit the latch housing to the top box using the original fixings and washers. Tighten the fixings to 1 Nm.

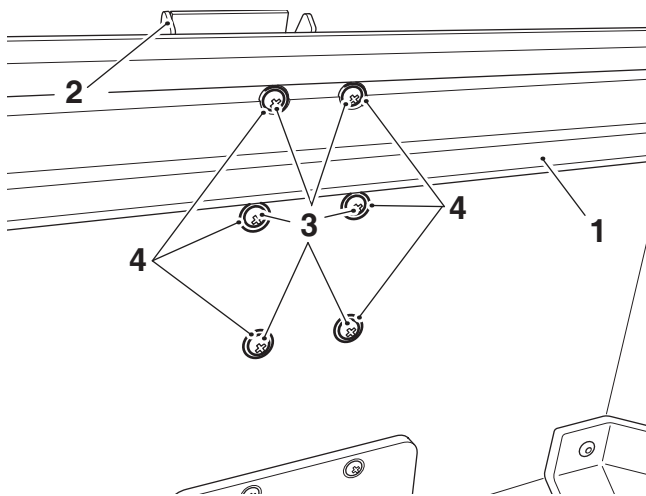

- Top box
- Latch housing
- Fixings
- Washers

- Fit the lock barrel referring to the appropriate Lock Barrel Fitment section on page 3 of this instruction.

### Warning

An incorrectly mounted top box may detach whilst riding, resulting in a dangerous riding condition.

Before riding, always make sure that the top box is mounted correctly. Make sure that the lock barrel is turned to the LOCK position and the key removed.

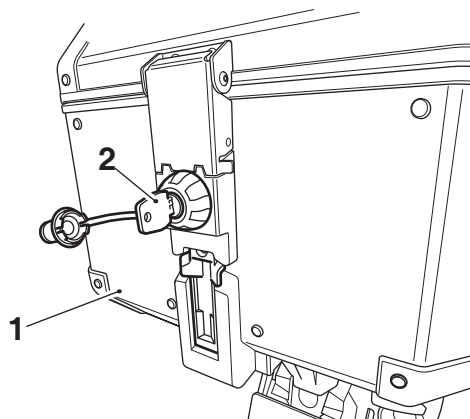

- Top box
- Lock position

A top box that detaches whilst riding may cause loss of motorcycle control and an accident and/or injury to other road users.



### Warning

The maximum safe load for the top box is 5 kg (11 lbs). Never exceed this loading limit as this may cause the motorcycle to become unstable leading to loss of motorcycle control and an accident.



### Warning

After fitting or removing the top box, operate the motorcycle in a safe area free from traffic to gain familiarity with the new handling characteristics. Operation when not familiar with the new characteristics of the motorcycle may result in loss of motorcycle control and an accident.



### Warning

Incorrect loading may result in an unsafe riding condition leading to loss of motorcycle control and an accident.

Always make sure any loads carried are evenly distributed on the motorcycle. Make sure that the load is correctly secured such that it will not move around while the motorcycle is in motion.

Evenly distribute the load within the top box. Pack heavy items at the bottom of the top box.

Always check the load security regularly (though not while the motorcycle is in motion) and make sure that the load does not extend beyond the rear of the motorcycle. Never exceed the maximum vehicle loading weight. Refer to the Owner's Handbook for the maximum loading weight specification.

This maximum loading weight is made up from the combined weight of the rider, passenger, any accessories fitted and any load carried.

For models that have adjustable suspension settings, make sure that front and rear spring preload and damping settings are suitable for the loading condition of the motorcycle. Refer to the Owner's Handbook.

Note the maximum permissible payload for the top box is stated on a label inside the top box.

## Cleaning the Luggage System

All parts of the luggage system fitted to your motorcycle must be cleaned regularly to avoid deterioration of their appearance.

### Washing

Prepare a mixture of cold water and mild automotive cleaner. Do not use a highly alkaline soap as commonly found at commercial car washes because it leaves a residue.

Wash the luggage system with a soft cloth. Do not use an abrasive scouring pad or steel wool. They will damage the finish.

Rinse the luggage system thoroughly.

Make sure no soap or water enters the inside compartment.

Dry the luggage system as far as possible with a soft cloth.

### Protecting

When the luggage system is dry, protect with a colourless lubricating spray.



### Caution

The use of abrasive cleaners and polishes will damage the system and must not be used.

It is recommended that regular protection be applied to the system as this will both protect and enhance the system's appearance.

### Note:

- **It is recommended to use the Triumph inner bags to protect both the luggage contents and the inner surfaces of the luggage.**



 **Warning**

If, after fitment of this accessory kit, you have any doubt about the performance of any aspect of the motorcycle, contact an authorised Triumph dealer and do not ride the motorcycle until the authorised dealer has declared it fit for use. Riding a motorcycle when there is any doubt as to any aspect of the performance of the motorcycle may result in loss of control of the motorcycle leading to an accident.

 **Warning**

This motorcycle must not be operated above the legal road speed limit except in authorised closed-course conditions.

 **Warning**

Only operate this Triumph motorcycle at high speed in closed-course, on-road competition or on closed-course racetracks. High-speed operation should only be attempted by riders who have been instructed in the techniques necessary for high-speed riding and are familiar with the motorcycle's characteristics in all conditions.

High-speed operation in any other circumstances is dangerous and will lead to loss of motorcycle control and an accident.

 **Warning**

Never ride an accessory-equipped motorcycle, or a motorcycle carrying a payload of any kind, at speeds above 80 mph (130 km/h). In either/both of these conditions, speeds in excess of 80 mph (130 km/h) should not be attempted even where the legal speed limit permits this.

The presence of accessories and/or payload will cause changes in the stability and handling of the motorcycle.

Failure to allow for changes in motorcycle stability may lead to loss of motorcycle control or an accident.

When riding at high speed, always be aware that various motorcycle configuration and environmental factors can adversely affect the stability of your motorcycle. For example:

- Incorrectly balanced loads on both sides of the motorcycle.
- Incorrectly adjusted front and rear suspension settings.
- Incorrectly adjusted tyre pressures.
- Excessively or unevenly worn tyres.
- Side winds and turbulence from other vehicles.
- Loose clothing.

Remember that the 80 mph (130 km/h) absolute limit will reduce by the fitting of non-approved accessories, incorrect loading, worn tyres, overall motorcycle condition and poor road or weather conditions.

 **Warning**

Never ride an accessory equipped motorcycle at speeds above 80 mph (130 km/h).

The presence of accessories will cause changes in the stability and handling of the motorcycle. Failure to allow for changes in motorcycle stability may lead to loss of control or an accident.

Remember that the 80 mph (130 km/h) limit will be reduced by the fitting of non-approved accessories, incorrect loading, worn tyres, overall motorcycle condition and poor road or weather conditions.