



## Accessory Fitting Instructions

Top Box Back Rest Pad Kit	
Kit Number	Models Affected
A9500730	Tiger 900, Tiger 900 GT, Tiger 900 GT Pro, Tiger 900 GT (LRH), Tiger 900 GT Aragon Edition, Tiger 900 Rally, Tiger 900 Rally Pro, Tiger 900 Rally Aragon Edition, Tiger 850 Sport, Tiger 1200 GT, Tiger 1200 GT Pro, Tiger 1200 Rally Pro, Tiger 1200 GT Explorer, Tiger 1200 Rally Explorer

Thank you for choosing this Triumph genuine accessory kit. This accessory kit is the product of Triumph's use of proven engineering, exhaustive testing, and continuous striving for superior reliability, safety and performance.

Completely read all of these instructions before commencing the installation of the accessory kit in order to become thoroughly familiar with the kit's features and the installation process.

These instructions should be considered a permanent part of your accessory kit, and should remain with it even if your accessory equipped motorcycle is subsequently sold.

### Note:

- **A9500730 can only be used in conjunction with the Expedition Top Box kits.**

### Parts Supplied:

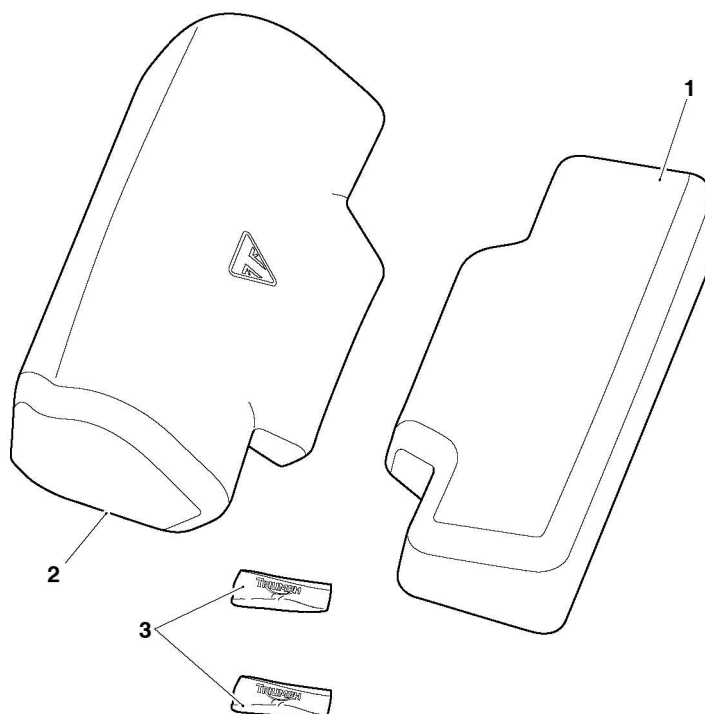

1. Backrest, lower pad	1 off	3. Cleaning wipe	2 off
2. Backrest, upper pad	1 off		

## Warning

The accessory kits covered in this instruction are designed for use on specific models of Triumph motorcycle. The accessory kits and the models applicable are listed at the start of the instruction. They should not be fitted to any other Triumph model or to any other manufacturer's motorcycle. Fitting an accessory kit to a Triumph model not listed, or to any other manufacturer's motorcycle will affect the performance, stability and handling of the motorcycle. This may affect the rider's ability to control the motorcycle and could cause an accident.

## Warning

Always have Triumph approved parts, accessories and conversions fitted by a trained technician of an authorised Triumph dealer. The fitment of parts, accessories and conversions by a technician who is not of an authorised Triumph dealer may affect the handling, stability or other aspects of the motorcycle's operation which may result in loss of motorcycle control and an accident.

## Warning

Throughout this operation, make sure that the motorcycle is stabilised and adequately supported to prevent risk of injury from the motorcycle falling.

### Note:

- **Once the backrest pads have been fitted, they will become an integral part of the top box and cannot be removed.**
1. If fitted, remove the top box as described in its instructions.

## Caution

Care must be taken when working on the top box. Damage to the top box surfaces may result from inadequate care while fitting the backrest pads.

2. Lay the top box on a flat, clean and soft surface.

## Lower Backrest Pad

### Note:

- **Read the warning notices printed on the cleaning wipe packet.**
  - **The surface to which the backrest pad is affixed must be clean and dry to make sure that the adhesive has a sound base to adhere to. Use the cleaning wipe supplied for this purpose.**
3. Using the cleaning wipe provided, clean the mounting area of the top box.

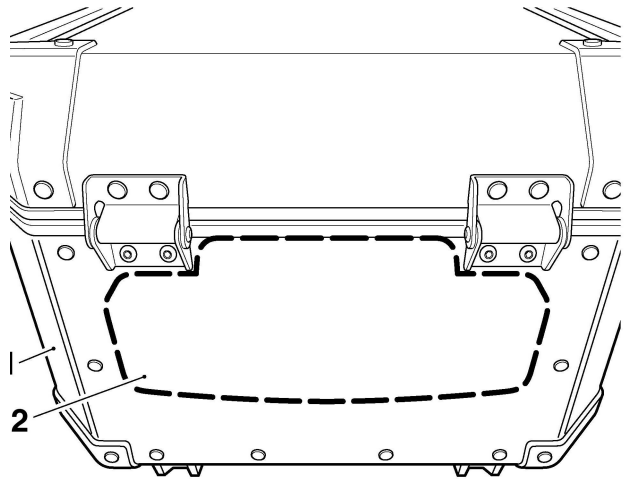

1. Top box
2. Cleaned area

## Caution

When fitting self-adhesive parts, care must be taken to make sure positioning is correct and accurate. Once the adhesive has been attached to the mounting surface, there is no satisfactory method of removal and repositioning if incorrectly aligned. Initial bonding is instant, full bonding is achieved after 72 hours.

4. Peel away the adhesive backing strips from the lower backrest pad.

### Note:

- **When positioning the lower backrest pad make sure it is located centrally between the hinges of the top box.**

- Carefully position the upper edge of the lower backrest pad to the lower edge of the rubber seal. Apply firm and even pressure to the entire lower backrest pad to make sure a good bond is achieved.

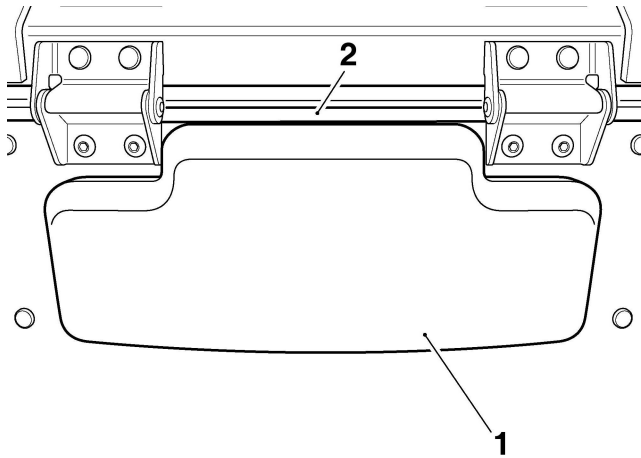

- Backrest pad (lower)
- Rubber seal

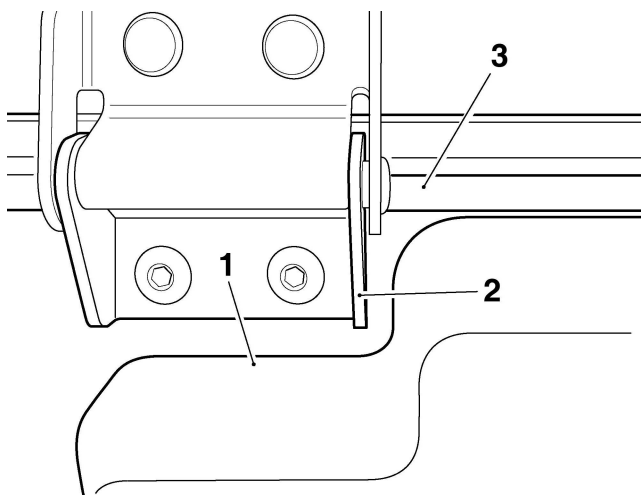

- Backrest pad (lower)
- Hinge (left hand shown)
- Rubber seal

## Upper Backrest Pad

### Note:

- Read the warning notices printed on the cleaning wipe packet.
  - The surface to which the backrest pad is affixed must be clean and dry to make sure that the adhesive has a sound base to adhere to. Use the cleaning wipe supplied for this purpose.
- Using the cleaning wipe provided, clean the mounting area of the top box lid.

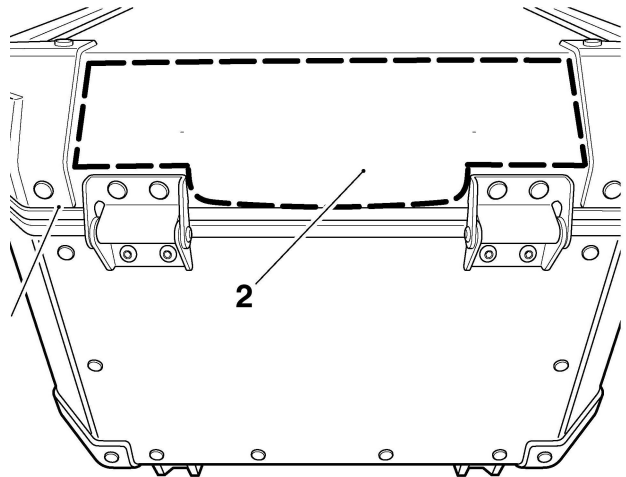

- Top box lid
- Cleaned area

- Cut two pieces of masking tape approximately 10 mm long, using scissors. The ends must be cut square.
- Mark a straight line on each piece of tape at 3.5 mm, as shown below.

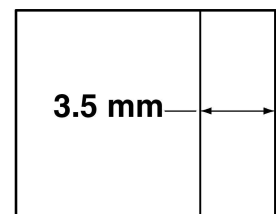
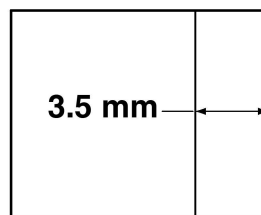

Markings on the Tape

- Position the two pieces of tape on the top box lid with the marked line level with the upper edge of the lid rim, as shown below.

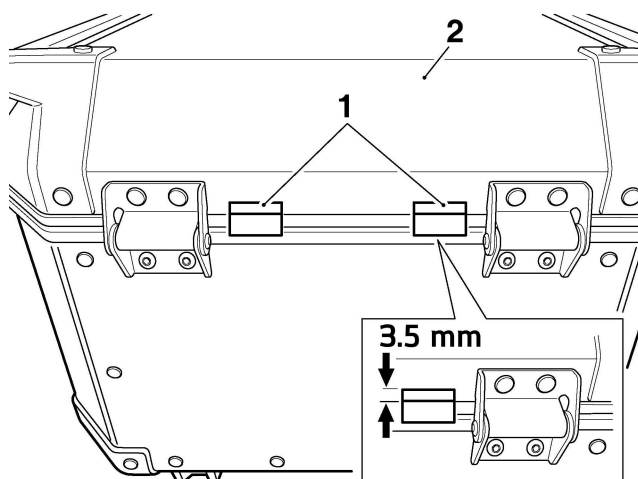

- Masking tape
- Top box lid



### Caution

When fitting self-adhesive parts, care must be taken to make sure positioning is correct and accurate. Once the adhesive has been attached to the mounting surface, there is no satisfactory method of removal and repositioning if incorrectly aligned. Initial bonding is instant, full bonding is achieved after 72 hours.

- Peel away the adhesive backing strips from the upper backrest pad.

### Note:

- When positioning the upper backrest pad make sure it is located centrally between the strap loops on the top box lid.
- Carefully locate the upper backrest pad to the top box lid to the upper edge of the masking tape. Apply firm and even pressure to the entire upper backrest pad to make sure a good bond is achieved.

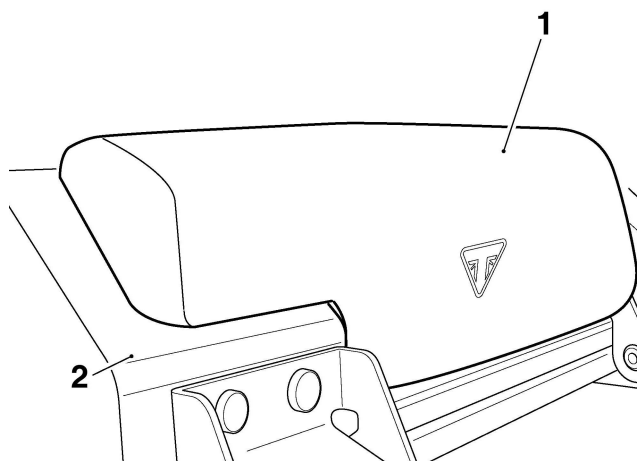

- Upper backrest pad
- Top box lid

- Remove the masking tape.
- Refit the top box as described in the relevant accessory fitting instructions.
- Check that the top box is securely locked to the sliding carriage.



### Warning

To prevent detachment of the top box while riding, after fitting always grasp the top box and pull firmly upwards and to the rear. If the top box is not correctly secured, it will detach from the sliding carriage. A loose or detached top box could cause loss of motorcycle control and an accident.

 **Warning**

Never ride an accessory-equipped motorcycle (including those fitted with Triumph approved windscreens and luggage systems) at speeds above 80 mph (130 km/h).

The presence of accessories such as windscreens and luggage systems will cause changes in the stability and handling of the motorcycle. Failure to allow for changes in motorcycle stability may lead to loss of control or an accident.

Remember that the 80 mph (130 km/h) limit will be reduced by the fitting of non-approved accessories, incorrect loading, worn tyres, overall motorcycle condition and poor road or weather conditions.

 **Warning**

If, after fitment of this accessory kit, you have any doubt about the performance of any aspect of the motorcycle, contact an authorised Triumph dealer and do not ride the motorcycle until the authorised dealer has declared it fit for use. Riding a motorcycle when there is any doubt as to any aspect of the performance of the motorcycle may result in loss of control of the motorcycle, leading to an accident.

 **Warning**

Only operate this Triumph motorcycle at high speed in closed-course, on-road competition or on closed-course racetracks. High-speed operation should only be attempted by riders who have been instructed in the techniques necessary for high-speed riding and are familiar with the motorcycle's characteristics in all conditions.

High-speed operation in any other circumstances is dangerous and will lead to loss of motorcycle control and an accident.

 **Warning**

The motorcycle must not be operated above the legal road speed limit except in closed-course conditions.