



## Accessory Fitting Instructions

<b>Dual Comfort Seat - Black</b>	
<b>Kit Number</b>	<b>Models Affected</b>
A2310132	Thruxton 1200, Thruxton 1200 R
<b>Dual Comfort Seat - Brown</b>	
<b>Kit Number</b>	<b>Models Affected</b>
A2310133	Thruxton 1200, Thruxton 1200 R
<b>Rider Comfort Seat - Black</b>	
<b>Kit Number</b>	<b>Models Affected</b>
A2310134	Thruxton 1200, Thruxton 1200 R, Thruxton TFC, Thruxton RS
<b>Rider Comfort Seat - Brown</b>	
<b>Kit Number</b>	<b>Models Affected</b>
A2310135	Thruxton 1200, Thruxton 1200 R, Thruxton TFC, Thruxton RS
<b>Low Rider Seat - Black</b>	
<b>Kit Number</b>	<b>Models Affected</b>
A2310136	Thruxton 1200, Thruxton 1200 R, Thruxton TFC, Thruxton RS

Thank you for choosing this Triumph genuine accessory kit. This accessory kit is the product of Triumph's use of proven engineering, exhaustive testing, and continuous striving for superior reliability, safety and performance.

Completely read all of these instructions before commencing the installation of the accessory kit in order to become thoroughly familiar with the kit's features and the installation process.

These instructions should be considered a permanent part of your accessory kit, and should remain with it even if your accessory equipped motorcycle is subsequently sold.

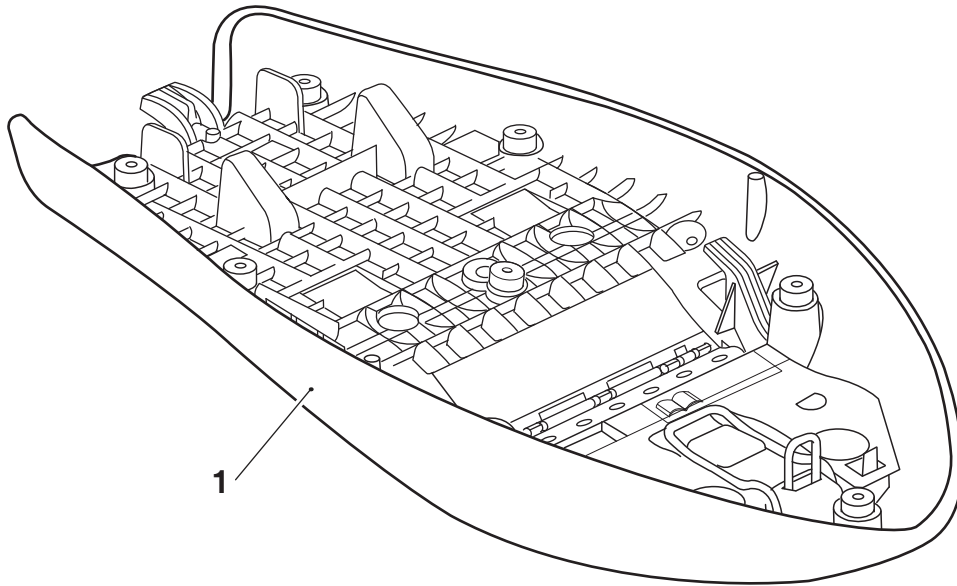

1. Seat	1 off		
---------	-------	--	--

**! Warning**

The accessory kits covered in this instruction are designed for use on specific models of Triumph motorcycle. The accessory kits and the models applicable are listed at the start of the instruction. They should not be fitted to any other Triumph model or to any other manufacturer's motorcycle. Fitting an accessory kit to a Triumph model not listed, or to any other manufacturer's motorcycle will affect the performance, stability and handling of the motorcycle. This may result in loss of motorcycle control and an accident.

**! Warning**

Always have Triumph approved parts, accessories and conversions fitted by a trained technician of an authorised Triumph dealer. The fitment of parts, accessories and conversions by a technician who is not of an authorised Triumph dealer may affect the handling, stability or other aspects of the motorcycle's operation which may result in loss of motorcycle control and an accident.

**! Warning**

Throughout this operation, ensure that the motorcycle is stabilised and adequately supported to prevent risk of injury from the motorcycle falling.

**Note:**

- **Triumph offers a broad range of approved genuine accessories for your motorcycle. We cannot therefore cover all possible equipment variations in these instructions. For removal and installation of Triumph Genuine Accessories, always refer to the instructions supplied with the respective accessory kit. To obtain additional copies of any Triumph accessory instructions, visit [www.triumphinstructions.com](http://www.triumphinstructions.com) or contact your authorised Triumph dealer.**

1. Remove the original seat, as described in the Service Manual. Retain the seat for reuse if the motorcycle is to be returned to its original condition.
2. Collect the seat from the kit.

**Note:**

- **Seat kits for these models include a central seat foot that must be fitted in the correct position before installation of the seat to the motorcycle.**

**Thruvton 1200, Thruvton 1200 R, Thruvton TFC Models Only**

3. Turn the seat over and remove the central foot from location A on the underside of the seat.

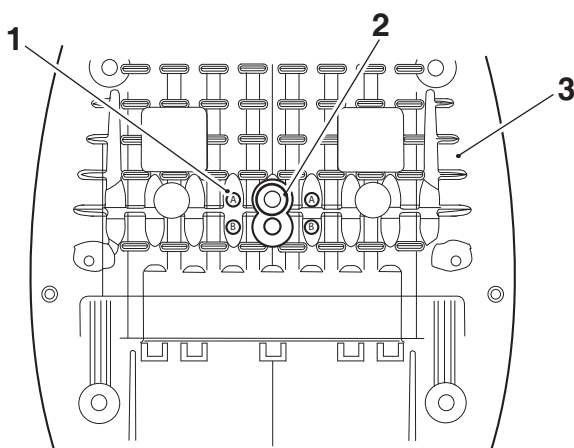

1. Location identifiers
2. Central foot
3. Seat, underside

4. Install the central seat foot to location 'B'.

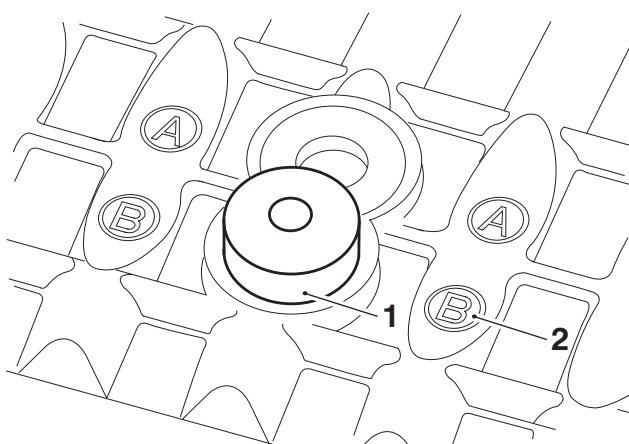

1. Central seat foot
2. Location identifier

**Thruvton RS Model Only**

5. The central seat foot must be left in position A on the underside of the seat.

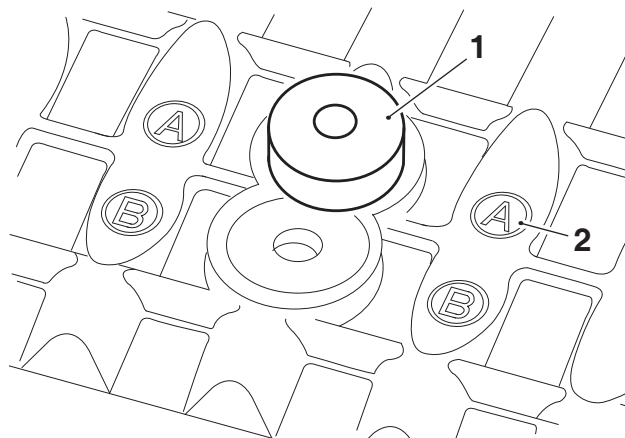

1. Central seat foot
2. Location identifier

**All Models**

**Warning**

Check for correct seat latch cable operation before fitting the seat. To prevent detachment of the seat during riding, after fitting, always grasp the rear of the seat and pull firmly upwards. If the seat is not correctly secured in the seat latch, it will detach from the seat latch. A loose or detached seat could cause loss of motorcycle control and an accident.

**Note:**

- **The method of fitting the accessory seat is the same as that for the original seat.**
6. Fit the accessory seat, as described in the Service Manual.

**Warning**

If, after fitting this accessory kit, you have any doubt about the performance of any aspect of the motorcycle, contact an authorised Triumph dealer and do not ride the motorcycle until the authorised dealer has declared it fit for use. Riding a motorcycle when there is any doubt as to any aspect of the performance of the motorcycle may result in loss of motorcycle control and an accident.



### Warning

Never ride an accessory-equipped motorcycle at speeds above 80 mph (130 km/h).

The presence of accessories will cause changes in the stability and handling of the motorcycle. Failure to allow for changes in motorcycle stability may result in loss of motorcycle control and an accident.

Remember that the 80 mph (130 km/h) limit will be reduced by the fitting of non-approved accessories, incorrect loading, worn tyres, overall motorcycle condition and poor road or weather conditions.



### Warning

Only operate this Triumph motorcycle at high speed in closed-course, on-road competition or on closed-course racetracks. High-speed operation should only be attempted by riders who have been instructed in the techniques necessary for high-speed riding and are familiar with the motorcycle's characteristics in all conditions.

High-speed operation in any other circumstances is dangerous and may result in loss of motorcycle control and an accident.



### Warning

The motorcycle must not be operated above the legal road speed limit except in closed-course conditions.